MEETING: Regular Town Council Meeting

DATE: March 17, 2025

TIME: 6:00 PM

PLACE: Town Council Chambers

Agenda

1. Call to Order

2. Land Acknowledgement

3. Approval of Agenda

4. Approval of Minutes

- Minutes of the Regular Council Meeting Minutes of February 18th, 2025, and Special Council Meeting February 25thth, 2025.

5. Presentations

5.1 WSP District Energy Feasibility Study

5.2 Antigonish Rivers Association - Allison White and Bailey Randall

6. Business from Minutes

7. Business from Committee of the Whole

7.1 Capital and Operating Reserve Options

8. New Business

8.1 Strategic Planning Priorities Update

8.2 In Camera per section 22 (2) of the MGA to discuss matters relating to;

- acquisition, sale, lease and security of municipal property
- labour relations;
- contract negotiations;and
- personnel matters.

8.3 Auditor Appointment

8.4 Solar Garden Temporary Borrowing – Ministerial Approval (Memo)

8.5 Electric Utility UARB Rate Adjustment (Memo)

8.6 Funding Application for the Northern Collector Project (CHIF)

8.7 Capital endorsement trunk and routes provincial submission (Memo)

8.8 Gaining a legal opinion re: AT Trail

9. Correspondence

9.1 Nova Scotia Association of Garden Clubs (NSAGC & Antigonish Garden Club

9.2 National Dental Hygienists Week – April 4-10, 2025

10. Staff Reports

11. Adjournment



DRAFT

**Regular Town Council
February 18, 2025
Town Council Chambers**

Present

Mayor S. Cameron
Deputy Mayor D. Roberts
Councillor P. McKenna
Councillor L. MacLellan
Councillor A. Murray
Councillor J. Pelly
Councillor J. Sullivan

Also in Attendance

R. Delorey, CAO
M. Fougere, Deputy Clerk
M. Barkhouse, Director of Corporate Services & Acting CAO
S. Long, Acting, Director of Community Development
K. Meisner, P. Eng., Director of Public Works
L. Roy, Strategic Initiatives

Members of the Gallery
Media

1. Call to Order

Mayor S. Cameron called the meeting to order at 5:17 PM.

2. In Camera

Mayor S. Cameron called for a motion to move the meeting in-camera at 5:21 PM to discuss matters relating to;

- acquisition, sale, lease and security of municipal property;
- personnel matters; and
- contract negotiations

It was Moved and Seconded “that council move in-camera”

Motion carried.

In-Camera adjourned at 6:15pm.

Council doors opened to the public.

DRAFT

Regular Council resumed at 6:21 pm. Mayor S. Cameron acknowledged that the meeting took place in the traditional and ancestral territory of the Mi'kmaq people, and that we are all treaty people.

3. Approval of Agenda

It was Moved and Seconded “to approve the agenda as amended.”

Motion carried.

4. Approval of Minutes

It was Moved and Seconded “to approve the minutes of January 20th as presented”

Motion carried.

5. Conflict of Interest

No conflicts declared.

6. Presentations/Flag Requests/Proclamation

6.1 RCMP – APP Consultation Presentation S/Sgt. Kimberly Hillier

S/Sgt. Kimberly Hillier of the Antigonish District RCMP Detachment presented the annual RCMP consultation update to Council, outlining the district's priorities, challenges, and policing efforts. Sgt. James Jessome was also in attendance.

The Antigonish Detachment consists of 22 regular members and 4 detachment assistants, with funding through Provincial and Municipal Police Agreements. The detachment responds to over 4,700 calls per year, with 13 frontline members handling day-to-day policing.

S/Sgt. Hillier emphasized the importance of continued collaboration between the RCMP, Council, and the community to maintain safety and security in Antigonish.

S/Sgt. K. Hillier noted that all RCMP officers in Antigonish are now equipped with body cameras to enhance accountability and transparency.

Council engaged in discussions, and the Mayor thanked S/Sgt. K. Hillier and Sgt. J. Jessome for their presentation.

6.2 2030 National Special Olympics Summer Games – Bob Hale

Bob Hale and Mark Chisholm presented to Council, showcasing a video from the 2018 Special Olympics National Games and discussing St. Francis Xavier University (STFX)’s bid to host the 2030 Games.

Highlights from the Presentation:

1,300 athletes participated in the 2018 National Games.

STFX is bidding to host the 2030 National Special Olympics Summer Games, with the bid due March 1st.

The 2018 Games had a major positive impact on Antigonish, boosting its reputation as a host for inclusive national events.

B. Hale noted they have Community & Organizational Support from Special Olympics Nova Scotia (NS), Antigonish Chamber of Commerce, Municipality of the County of Antigonish

St. Francis Xavier University (STFX) as a key hosting partner.

Councillor discussions ensued.

A Special Council Meeting will be scheduled within the next week to further discuss the funding request and make a final decision.

Mayor and Council thanked Bob Hale and Mark Chisholm for their presentation and efforts in bringing this opportunity to Antigonish.

6.3 Antigonish Art Fair - Beth Latwaitis & Joan MacDonald

Beth Latwatis and Joan MacDonald took the podium to provide an overview of the Antigonish Art Fair and its development, recognizing the late David Miller as a key contributor.

B. Latwaitis shared the Art fair's history, starting in June 2013, and the establishment of the Arts House at the former Visitor Information Centre, where the Arts House remains currently.

Arts House has engaged 930 students and provides creative space for artists, including newcomer Nataliia Dolomanska. It also features a health-approved rental kitchen.

The upcoming Art Fair is set to begin on June 27th. J. MacDonald elaborated on their ambitious vision. The event, running from late June to the end of August, remains free.

Councillor discussions ensued.

Mayor and Council thanked both B. Latwatis and J. MacDonald for coming in to present.

Mayor S. Cameron noted that council will break for a 5-minute recess at 7:29pm

The Meeting reconvened at 7:40 pm.

7. Business from Minutes

7.1 (a) Town Council Advisory Committee Policy – Proposed Amendment

R. Delorey provided an update to council on the proposed amendment to the current Advisory Committee Policy.

Recommended Motion

To accept the amended Advisory Committee Policy as presented, with the following amendments:

- Addition of three new committees (Nominations, Recreation, and Infrastructure)
- Consolidated the meeting default meeting schedule (as called by the chair) under general policy rather than within each individual committee section
- Clarified that priority consideration for community appointments to all committees is given to Town residents, but other residents may be appointed
- CAO may sit as a non-voting member of any committee
- Individual Committee memberships updated that Deputy Clerk or Designate (rather than CAO or designate) sits as secretary
- Added consistent reference to Director or Designate for each committee as a non-voting staff member representative.
- Housekeeping language updates – typos, grammar, etc..

It was Moved and Seconded “to accept the amended Advisory Committee Policy as presented.”

Motion Carried.

7.1(b) Appointed members of Council to various Town Council Advisory Committees

Recommended Motion:

The Town of Antigonish appointed members of Council to various Town Council Advisory Committees at the November 18, 2024 Regular Council Meeting. To ensure accurate representation and participation the Town of Antigonish hereby

repeals all previous appointments of members of Council to Town Advisory Committees and appoints the following members to the respective committees, effective February 18, 2025:

- Accessibility Committee: Chair Councillor Patrick McKenna, Mayor Sean Cameron
- Beautification Committee: Chair Councillor Andrew Murray, Councillor Leon MacLellan, Councillor Patrick McKenna
- Fire Committee: Chair Deputy Mayor Diane Roberts, Councillor Juanita Pelly, Councillor Jack Sullivan
- Infrastructure Committee: Chair Councillor Jack Sullivan, Deputy Mayor Diane Roberts, Councillor Leon MacLellan
- Nomination Committee – Chair Mayor Sean Cameron, Deputy Mayor Diane Roberts, Councillor Andrew Murray.
- Police & License Committee: Chair Deputy Mayor Diane Roberts, Councillor Patrick McKenna, Councillor Jack Sullivan
- Planning Advisory: Chair Councillor Jack Sullivan, Mayor Sean Cameron, Councillor Leon MacLellan
- Recreation Committee: Chair Councillor Juanita Pelly, Deputy Mayor Diane Roberts
- Waste Management Committee: Chair Councillor Leon MacLellan, Councillor Patrick McKenna, Councillor Jack Sullivan

It was Moved and Seconded, “to accept the amended advisory committee policy as presented with the following amendments.”

Motion Carried.

Discussions ensued.

7.2 Snow Removal Policy for Street Parking Meters

Mayor S. Cameron made a Motion to Repeal the Policy.

Motion

It was Moved and Seconded “to repeal the Snow Removal Policy for Street Parking Meters.”

Motion Carried.

Discussions ensued.

Concerns were raised about the lack of a snow removal policy, particularly its impact from the curb to the sidewalk.

A suggestion was made to review the policy at the next Infrastructure Committee meeting.

The rationale for repealing the policy was explained, with an emphasis on developing a new one.

7.3 ASAP funding request

This request was deferred from January 20th Regular Council Meeting. There was a motion made to approve the funding request.

Motion

It was Moved and Seconded “to approve \$3,500.00 to the ASAP group.”

Amendment:

Councillor D. Roberts proposed an amendment to reduce the amount to \$2,000.00 seconded by Councillor P. McKenna. The amendment was defeated.

Motion Carried.

7.4 Eastern U16 Challenge/U18 Cup STFX

This request was deferred from January 20th Regular Council Meeting. There was a motion made to approve the funding request.

Motion

It was Moved and Seconded “to provide \$10,000 to the U16 Challenge/U18 Cup STFX.”

Council discussions followed. Councillor L. MacLellan requested for some type an analysis of the event, and CAO R. Delorey suggested using the 2018 Special Olympics as a reference if the decision was deferred.

Councillor J. Pelly made a motion to defer this request to a special council meeting at another date.

Motion

It was Moved and Seconded “to defer the funding request to the Special Council Meeting on February 26th, 2025.

Motion carried.

8. New Business

8.1 Electric and Water Account Write-offs

M. Barkhouse distributed a list of old electric utility and water accounts to be written-off. She took to the podium and provided Council with details for a total of \$63,825.75.

Recommended Motion:

That Council approve the write-off of the presented ninety-two (92) inactive electric utility accounts and four (4) inactive water and sewer utility accounts totaling \$63,825.75.

It was Moved and Seconded “That Council approve the write off as presented totaling \$63,825.75.”

Motion Carried.

8.2 Tax Sale Approval

M. Barkhouse presented a list of five property tax accounts and made the following recommendation to council.

Recommended Motion:

"That Council approve the following five properties for tax sale, as per Municipal Government Act and the Town of Antigonish Tax Collection Policy:

AAN: 00740268

AAN: 01235656

AAN: 02745038

AAN: 03140989

AAN: 07961324

It was Moved and Seconded “That Council approve the tax sale of five properties.”

Motion Carried.

8.3 Highway 4 Church St. Roundabout – Kyle Meisner, P.Eng., Director of Public Works

Motion

Council approves entering into agreement with the Province of Nova Scotia and the County of Antigonish to complete the trunk 4 and Church St. round about, with a commitment of up to \$205,000 to cover one third (1/3) of municipal design /inspection costs and one half (1/2) of the municipal water meter and line costs.

Motion Carried.

8.4 Appointment of Town Council Members to Community Committees Policy

CAO, R. Delorey spoke – one thing with or without the policy not much changes. Board does not have a seat. Antigonish Transit Society has a seat reserved for the Town. If the Town chooses to exercise, then they are appointed to the board.

Motion to repeal

It was Moved and Seconded “to repeal the Appointment of Town Council Members to Community Committees Policy.”

Motion carried.

Discussions ensued.

8.5 Procurement Policy

Mayor S. Cameron expressed concerns about the policy, citing inefficiencies. Referring to a motion adopted at the December 16th Regular Council Meeting, on Flood Protection. He noted that requiring a tendering process for minor matters, due to the lack of standing offers, was an unnecessary use of Town staff time. The motion was revisited in the new year, and he found the policy cumbersome.

Discussions ensued.

CAO R. Delorey explained that while a standing offer would streamline the process. He welcomed the opportunity to revisit the policy.

8.6 Live Streaming (Councillor P. McKenna)

Councillor P. McKenna advised council that he would like to make the following motion.

Motion

It was Moved and Seconded that “The Town will develop a policy and budget to enable live streaming of Town Council meetings, upon adoption of the policy and any necessary technological investments, the Town of Antigonish will proceed with live streaming Town Council meetings in accordance with the policy.”

Motion Carried.

Discussions ensued.

8.7 Addressing Issues with Delinquent Landlords (Deputy Mayor D. Roberts)

Deputy Mayor D. Roberts brought forward concerns regarding a housing situation she encountered after receiving a call from a town resident. The issue was related to the poor condition of a rental property, which she believed should be condemned.

On a positive note, Deputy Mayor Roberts reported that the tenant will be relocating at the beginning of March.

Discussions ensued.

CAO, R. Delorey clarified a few key points;

That all landlord-tenant matters fall under the Tenancy Board Act, which governs disputes between both parties. In this case, the residents' issue would fall under the Tenancy Board Act.

The Unsightly Premises By-Law allows the municipality to intervene in property conditions.

The Building Code (enforced by EDPC) would determine if a property should be condemned.

Both By-Law Enforcement and EDPC will work together to address the issue.

Residents should be encouraged to file complaints through appropriate channels.

Relevant information will be forwarded to By-Law Enforcement for further action.

Discussions ensued.

8.8 Municipal Response to U.S. Tariff Threats (Councillor L. MacLellan)

Tariffs threaten the economic security of our town, province, and country. Municipal leaders across Canada are standing up and speaking out against the impact that 25% U.S. import tariffs—including those now set to come into force against Canadian steel and aluminium in March—would have on our communities. Even though Canada was able to delay the implementation of more general tariffs until March 1, a severe threat to our economy and the vital Canada-U.S. relationship remains.

Motion:

It was Moved and Seconded "That the Town of Antigonish Council supports the municipal, provincial, and federal governments' efforts to respond to the threat of US tariffs.

Motion carried.

8.9 Pucks for Purpose

Correspondence was communicated to all Council members.

Motion

It was moved and seconded that the Town purchase a table at the Pucks for purpose Banquet for \$375.00.

Motion Carried.

DRAFT

9. Correspondence

9.1 Sodexo (Follow up from Jan 20 Council meeting)

Town Council since received a letter from Sodexo to Decline the funds approved.

9.2 Minister EM -Emergency Management (Jan 17)

Minister sent a Letter that was circulated to council for information purposes.

9.3 2025 REP Provincial Spelling Bee – May 10

Council received a funding request via email for sponsorship of the 2025 REP Provincial Spelling Bee.

Motion

It was moved and seconded “that the Town of Antigonish sponsor at the silver level of \$500.00 to the 2025 REP Provincial Spelling Bee, May 10th, 2025”

Motion Carried.

10. Staff Reports

CAO R. Delorey informed the council that a Special Council Meeting is scheduled for Tuesday, February 25th, followed by an Audit Committee meeting.

He also recommended holding Committee of the Whole meetings on the first Tuesday of each month.

Motion

It was Moved and Seconded “to make Committee of the Whole meet the first Tuesday of each month. Start at 6:00 PM.

Motion Carried.

10. Council Reports

Mayor D. Roberts, attended three committee meetings, as well as African Heritage Town and STFX event.

Due to the length of this meeting, Council decided to defer the council reports to the first Committee of the Whole meeting on March 4th.

11. Adjournment

With no further business, the meeting was adjourned at 10:04 PM.

DRAFT

**Special Town Council Minutes
February 25, 2025
Town Council Chambers**

Present

Mayor S. Cameron
Deputy Mayor D. Roberts
Councillor L. MacLellan
Councillor P. McKenna
Councillor A. Murray
Councillor J. Pelly
Councillor J. Sullivan

Also, in Attendance

R. Delorey, CAO
M. Fougere, Deputy Clerk

M. Barkhouse, Director of Corporate Services
K. Misener, P.Eng., Director of Public Works

1. Call to Order

Mayor S. Cameron called the meeting to order at 6:03 PM.

2. Approval of Agenda

It was Moved and Seconded “to approve the agenda as presented.”

Motion carried.

3. Business from Minutes

3.1 2030 National Special Olympics Summer Games

R. Delorey presented a detailed financial analysis based on data from the 2018 Special Olympics event held at St. Francis Xavier University. The analysis was based on 2018 data and assumed similar economic conditions.

Council discussions followed, with concerns raised about the funding sources and economic returns.

Mayor noted that since 2017 Council provides \$0.01 / \$100 of assessment approximately \$53,000 per year (based on this fiscal) to StFX University for facilities. He suggested redirecting those funds to this request instead of drawing from the discretionary funds, because he was advised StFX is considering closing the pool.

Motion

It was Moved and Seconded “That Town Council sponsor \$100,000 dollars to support the 2030 Special Olympics Summer Games.”

Discussions ensued

Amendment: Deputy Mayor D. Roberts moved to amend the motion to reduce the contribution to \$75,000.

Amendment Defeated

Motion carried.

3.2 Eastern U16 Challenge/U18 Cup STFX – Football Nova Scotia

R. Delorey provided a financial analysis of impact same as the 2030 Special Olympics. Football Nova Scotia Funding Request \$10,000

Discussions from Council was discussed.

Motion

It was Moved and Seconded “to donate \$10,000 dollars to the Eastern U16 Challenge Cup/U18 Cup STFX.”

Motion carried.

4. Adjournment

It was Moved and Seconded “to adjourn at 6:39 pm.”

Motion carried.



March 17, 2025

Lise Roy

Strategic Initiatives Coordinator

THE TOWN OF
ANTIGONISH



ST. FRANCIS XAVIER
UNIVERSITY

Community District Energy System
Final Feasibility Report Presentation

Prepared by:

Brian Warren, P.Eng. – Team Lead, M&E

Matthew Rodgers, P.Eng. Project Manager Mechanical

Gardiner MacNeill, P.Eng. Senior Electrical Engineer



Sources of Funding



FINAL SOURCES OF FUNDING				
Total cost of Study	Amount	Funding Source	Amount	% of Funding
WSP Canada	\$475,000	Green Municipal Fund	\$175,000	33%
Non-Rebatable HST	\$20,363 (4%)	Sustainable Communities Challenge Fund	\$300,000	57%
Staff time	\$32,747	Town of Antigonish	\$53,110	10%
Submitted to Funders	\$528,110			
			\$528,110	100%

90%



Town of Antigonish Pathway to Zero Emissions Community District Energy System Feasibility Study

WSP Canada



Agenda

- 1) **Introductions**
- 2) **Project Statement**
- 3) **Phase 1 Summary**
- 4) **Phase 2 Summary**
- 5) **Technology Review**
- 6) **Energy Recovery Opportunities**
- 7) **Next Steps**
- 8) **Q&A**



Project Statement

- *To recommend the most cost effective (capital investment and long-term operation) district energy system for the Town of Antigonish that will contribute to the Town's goal of being the first Net Zero community in Canada.*

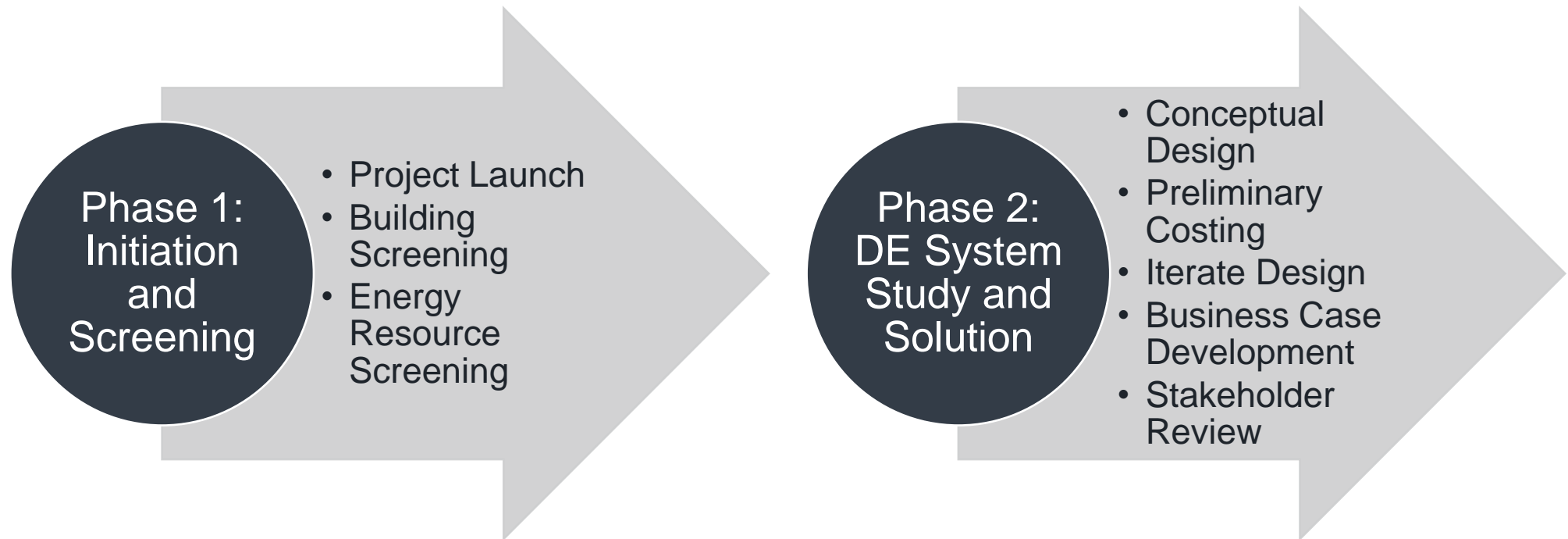

Phase 1 Summary

- Steam Meter Data from StFX
 - 15-minute steam meter readings from majority of buildings
 - Review of Secondary Side LTHW Supply Temperature, Return Temperature, Reset (Summer/Winter) Schedule
- Energy/Load Modeling
 - IESVE software was used for energy analysis for buildings with insufficient load data
 - Utility billing review
- Facility visits/operator discussions



Phase 2 Summary

- Technology Review
- Solution Development: 3 Options reviewed and evaluated
 - Heat Pumps + Electric Boilers
 - Electric Boilers Only
 - Electrode Steam Boilers
- Buried piping routing and preliminary sizing
- Hydraulic analysis with FluidIt™ Heat
- Proposed plant equipment layouts & Schematics
- Building connection P&IDs
- Preliminary Costing of Proposed Options
- Business Case Development via O&M Costing

Technology Review – Central Plant Technologies

- ❑ **Central Plant Technologies**
- ❑ Electric Resistance Boilers
- ❑ Advantages
 - ❑ High efficiency (99%)
 - ❑ Low maintenance (no moving parts)
 - ❑ High turndown ratio
 - ❑ No reliance on return temperatures for maximum efficiency
- ❑ Disadvantages
 - ❑ High power draw, reliance on grid stability
 - ❑ Reliance on strict water treatment regimen



Technology Review – Central Plant Technologies

- ❑ **Central Plant Technologies**
- ❑ Geothermal Exchange
 - ❑ Leverages relatively stable temperatures below grade
 - ❑ Uses earth as a thermal energy reservoir
 - ❑ Thermal energy can be extracted and boosted by water-source heat pump technology
- ❑ Advantages
 - ❑ Stable year-round performance
 - ❑ Low carbon footprint
- ❑ Disadvantages
 - ❑ Large footprint required
 - ❑ Optimal performance requires balance in heating and cooling load. Unbalanced load requires further measures to maintain performance

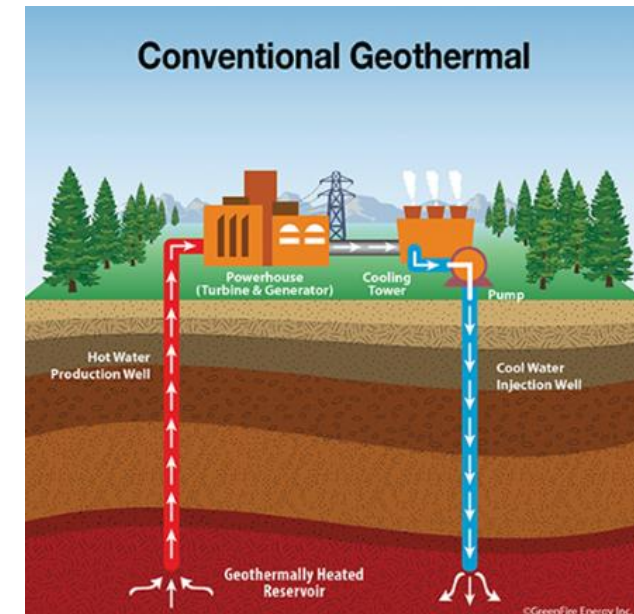

Technology Review – Central Plant Technologies

- ❑ **Central Plant Technologies (cont'd)**
- ❑ Water-Source Heat Pumps
- ❑ Advantages
 - ❑ High efficiency (COP > 2.5 in heating)
 - ❑ High turndown ratio
- ❑ Disadvantages
 - ❑ High power draw, reliance on grid stability
 - ❑ Reliance on strict water treatment regimen

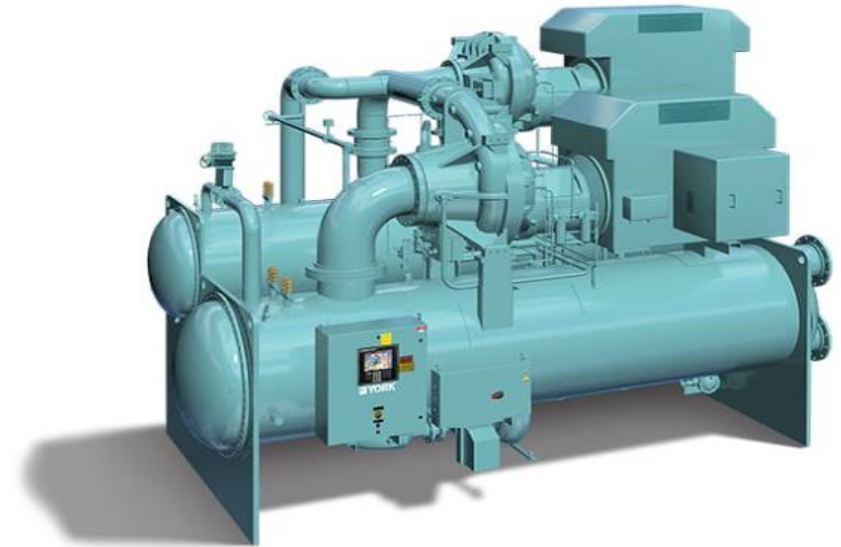

Technology Review – Central Plant Technologies

- **Central Plant Technologies (cont'd)**
- Wastewater Heat Recovery with Heat Pumps
- Advantages
 - Utilizes low-grade waste heat
 - High efficiency (COP > 2.5 in heating)
 - High turndown ratio
- Disadvantages
 - Capital cost
 - Additional maintenance to wastewater management infrastructure

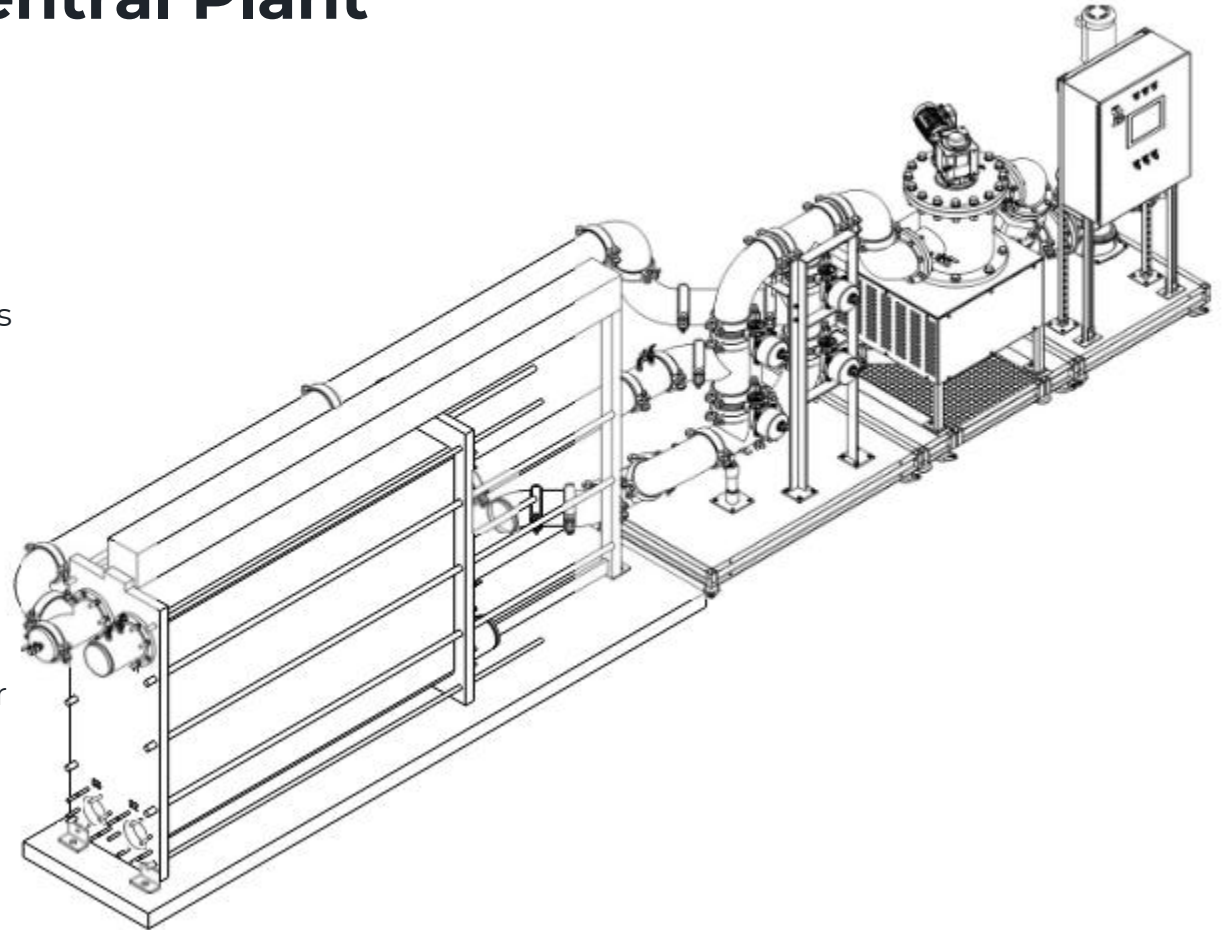

Technology Review – Low Temperature Hot Water Distribution

- ❑ **European Standard (EN) Factory Insulated Piping (LOGSTOR)**
- ❑ Pre-insulated carrier piping with integral leak detection

The system component include:

- 1** Service pipe: steel.
- 2** Insulation: polyurethane foam.
- 3** Outer casing: polyethylene, HDPE.
- 4** Leak Detection: two 1.5 mm² copper wires for surveillance. One wire is tinned.
- 5** Pipe Label.

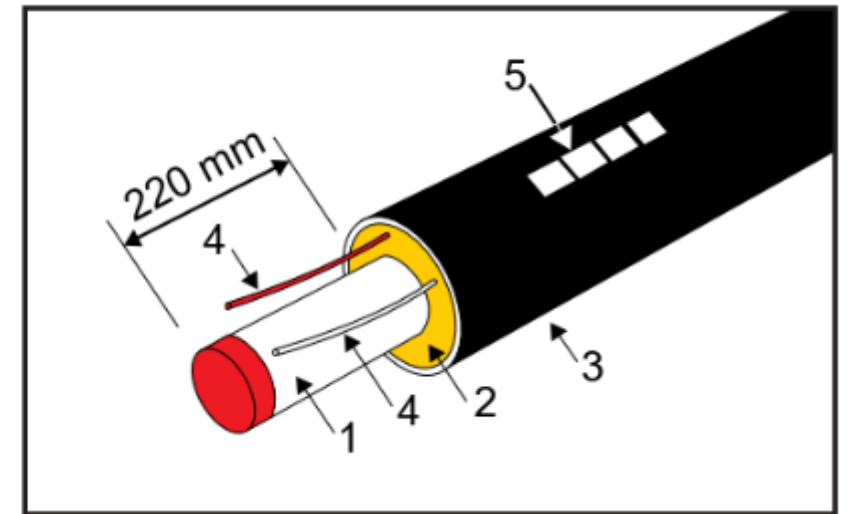

Proposed Buried Piping Network

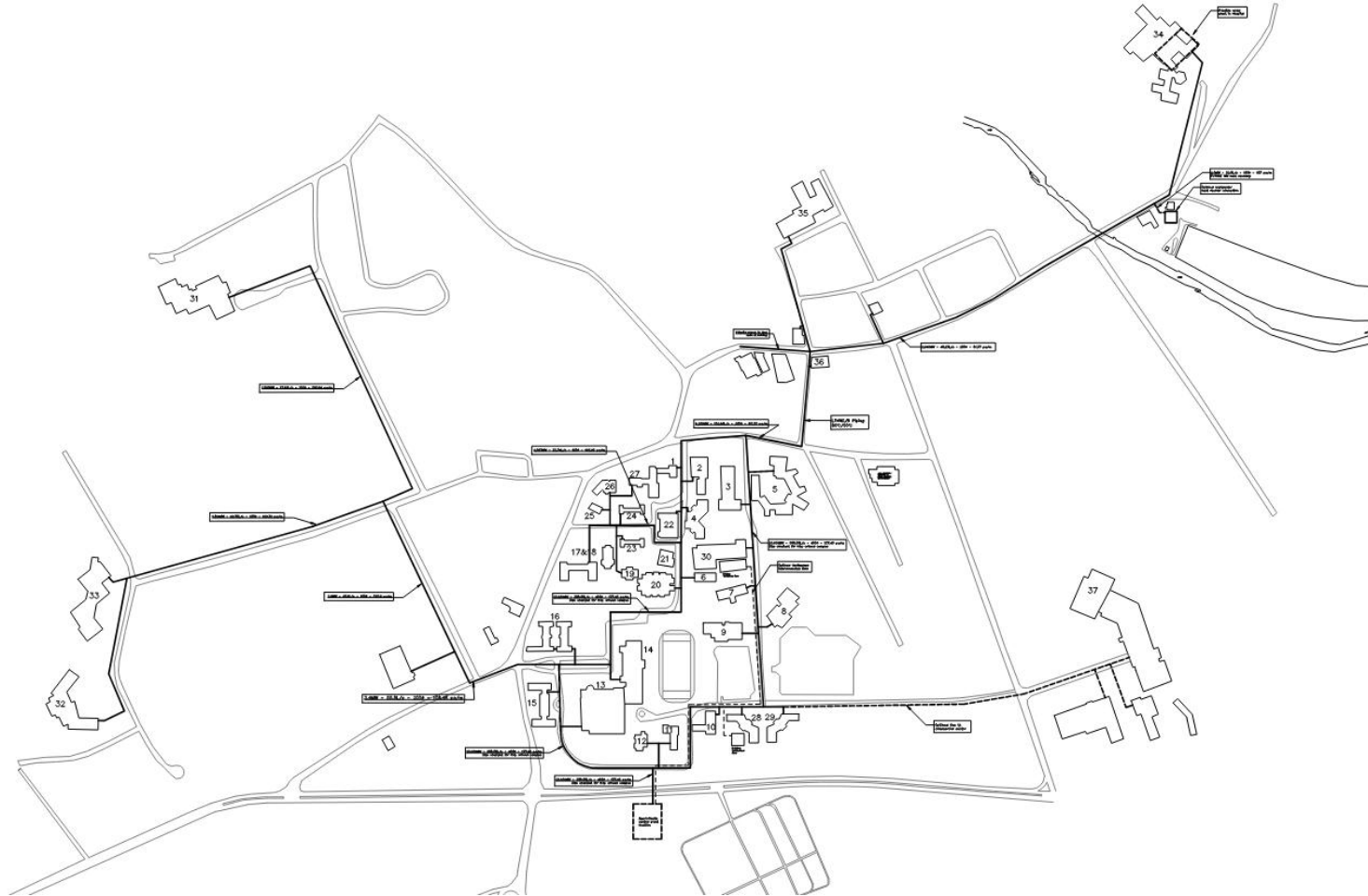

Energy Recovery Opportunities

- Wastewater Heat Recovery
 - Year-round heating energy provided from Antigonish wastewater
 - Wastewater Heat Recovery technology coupled with Water-Source Heat Pump Technology could provide up to 2 MW of heat for CDES network

- St Martha's Regional Hospital
 - Aging oil-fired high-pressure steam heating system (3 MW)
 - Aging chilled water cooling system
 - Could benefit from community district energy connection
 - Improved energy efficiency and resiliency
 - Decarbonize hospital energy
 - Heat rejected from year-round cooling can be used by new district heating network

- Bottom Line: St. Marthas and TOA wastewater plant can save energy and reduce greenhouse gases together

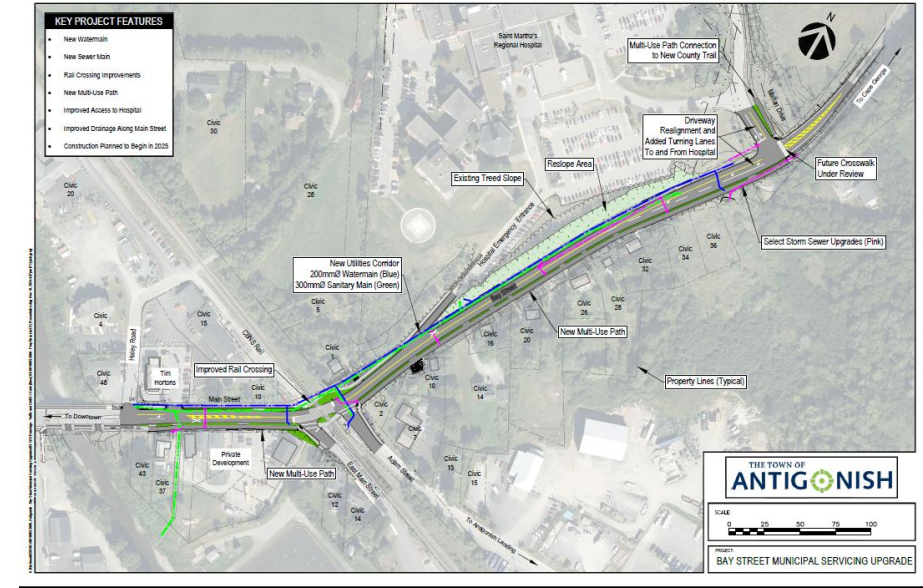

Next Steps

- **Further study recommended:**
 - **Hospital energy study**
 - **Wastewater study**

- **Town of Antigonish**
 - **Explore infrastructure project synergies**
 - **Bay St Municipal Services**
 - **AT Path/Buried Energy Piping**



Thank you



wsp.com

ANTIGONISH RIVERS ASSOCIATION

An overview of local projects, benefits to the community and important partnerships



Through a significant funding contribution from Environment and Climate Change Canada (ECCC), the ARA was able to complete an aquatic restoration project in the Ohio River and put together this informative presentation with the purpose of educating our community in freshwater issues and to promote the partnerships that allow us to successfully complete high-impact projects.



**Government
of Canada**

**Gouvernement
du Canada**

What is the ARA?

ARA's mandate is to protect and enhance the ecological integrity of the aquatic ecosystems in Antigonish Town & Country with the goal of:

- Sustaining a healthy fishery resource
- Promoting responsible angling for all community members
- Supporting angler education



2024 Funding Partners



OUTDOOR FUND



- The ARA is a non-profit and is largely run by volunteers
- Ecological-centered funding
- Core Funding:
 - ARA's Biennial Salmon Dinner and Auction (\$15,000/yr)
 - Sportfish Habitat Fund (\$25,000/yr)
 - Town of Antigonish (\$10,000/yr)
- Leverage core funding to increase annual budget by x4 the amount

Collaboration

- Working with other conservancy groups, local governments, and community members:
 - Nova Scotia Salmon Association
 - Foundation for the Conservation of Atlantic Salmon
 - Atlantic Salmon Federation
 - Confederacy of Mainland Mi'kmaq
 - Town of Antigonish
 - Local river/angling associations in the province
 - St. FX and NSCC
 - Local landowners/farmers



The Confederacy of
Mainland Mi'kmaq



nscc



ST. FRANCIS XAVIER
UNIVERSITY



Local Connections

- Developing connections with local landowners and farmers is highly valued
- Riparian planting/reforestation, bank erosion remediation and flood control
- ARA could be a resource for the Town & County
- 2 Billion Trees Initiative
 - Provides funding to the ARA which in turn provides trees, equipment and labour at no cost to the landowner
 - No contingencies about river/riparian proximity

Economic Potential of Thriving Watersheds

- Healthy watersheds provide opportunities for physical and mental wellness, as well as economic potential for our community
- Recreational fishing has low-cost barrier to participate
- Economic Impact Assessment Survey:
 - 100 anglers surveyed
 - West River and tributaries
 - Amount of money participants spent on food, accommodations, equipment, entertainment, guides, etc. in Antigonish during fishing season
 - \$1,000,000 spent annually
- Ongoing restoration projects help to limit flooding and ice jams through Town



Project Overview

Why river restoration is done and
its importance





2021 - Over Widened



2024 - Channel Narrowed

BRIERLY BROOK

- Nursery stream, has been severely degraded
- Research and restoration site for over 30 years
- Highway 104 Twinning offsetting project results:
 - 4.5km of river restored in upper Brierly Brook
 - 5000+ trees planted
 - Channel significantly over-widened in 2021, in 2024 found to have narrowed by 50%
 - A significant increase in Salmon and trout numbers since 2021 in all freshwater life stages

JAMES RIVER

- James River dam creates unique challenges:
 - Barrier to fish passage and sediment flow
 - Low flow throughout the summer
 - Channel over-widened and straightened
- Town of Antigonish provides ARA a yearly budget for habitat restoration in James River
- 2021 Spawning gravel project:
 - 2km restored area
 - Over 160 tons of clean spawning gravel annually
 - Since 2021, the number of adult salmon and trout returning to spawn has drastically increased and the abundance of juvenile salmonids has gone up





OHIO RIVER

- Logging had long-lasting impacts on the river:
 - Over-widened
 - Disconnected from floodplains
 - Straightened
- Ohio River provides excellent cold water refuge areas
- The 2024 Ohio Project resulted in 2.5km of stream restored with 560 trees planted
- This project site was the scene of multiple training sessions that ARA hosted for CMM, another way to collaborate
- This project was one of the first selected in Canada as part of the Atlantic Salmon Federations expansion of the Headwaters Program
- Environment and Climate Change Canada was a major funding partner



Community Connection Projects

- Annual Brierly Brook Garbage Clean-up
- Annual Fishing Derby
- Winter Fly Tying Sessions
- Designated angler parking area at Six Maples Farm in Addington Forks
- Cameron Lake Barrier-Free Recreation Area

Cameron Lake Barrier-Free Recreation Area

- Located in Pinevale
- The County of Antigonish was a significant funding partner for this project
- The site includes:
 - Accessible Ramp and Floating Dock
 - Boat Launch
 - Picnic Shelter
 - Small parking area



To Conclude

- ARA works with and for the County of Antigonish to address serious freshwater issues affecting the environment, landowners, farmers and businesses
- Healthy populations of Atlantic Salmon and Brook Trout has proven to be an economic stimulus to Antigonish
- Restoration efforts aid in flood control and ice jams through Town
- Any Questions?



To: Town of Antigonish Council
Randy Delorey, Chief Administrative Officer

Submitted by: Meaghan Barkhouse, Director of Corporate Services

Date: Thursday, March 13, 2025

Subject: Temporary Borrowing Resolution (TBR) – Community Solar Garden

Background:

The previous Temporary Borrowing Resolution (TBR) and ministerial approval for the Community Solar Garden project elapsed in February 2025, and the temporary loan associated with it has been fully repaid to our financial institution. However, the Town is currently ineligible to enter into a Municipal Finance Corporation (MFC) debenture, as the Community Solar Garden is not operational, and the ministerial approval expired. It was expected for the Town to have access to this financing in May 2025.

Due to project delays, which have extended beyond the original expected completion date, the Town is submitting a Temporary Borrowing Resolution for \$4,015,000. This borrowing amount has been updated to reflect the current financial obligation as the overall budget increased from \$5.4M (2021) to \$8.0M (2025), excluding any expected recovery due to our insurance claim. This TBR will cover a 24-month period to ensure that the project is completed within the next year while also allowing for contingency time.

Rationale:

- MFC loans are only granted twice a year, meaning timing constraints must be considered.
- Ministerial approval associated with the TBR must not expire before the financing can be secured.
- This TBR will account for all costs incurred within the project.
- The additional time ensures financial flexibility in case of further unforeseen delays.

Recommendation:

We request that the attached Temporary Borrowing Resolution be approved by Council to begin the process of accessing temporary borrowing for the Community Solar Garden and have the required approvals to enter into a MFC debenture when the Solar Garden meets its eligibility criteria.

MUNICIPAL COUNCIL OF THE

Town of Antigonish

TEMPORARY BORROWING RESOLUTION

Amount: \$ 4,000,000

Purpose: Community Solar Garden

WHEREAS Section 66 of the Municipal Government Act provides that the Council of the Town of Antigonish, subject to the approval of the Minister of Municipal Affairs and Housing, may borrow to expend funds for a capital purpose as authorized by statute;

WHEREAS the Council of the Town of Antigonish has adopted a capital budget for this fiscal year as required by Section 65 of the Municipal Government Act and are so authorized to expend funds for a capital purpose as identified in their capital budget; and

WHEREAS the Council of the Town of Antigonish has determined to borrow the aggregate principal amount of four million dollars Dollars (\$ 4,000,000) for the purposes of Community Solar Garden;

BE IT THEREFORE RESOLVED

THAT under the authority of Section 66 of the Municipal Government Act, the Council of the Town of Antigonish borrow a sum or sums not exceeding four million dollars Dollars (\$ 4,000,000) for the purpose set out above, subject to the approval of the Minister of Municipal Affairs and Housing;

THAT the sum be borrowed by the issue and sale of debentures of the Council of the Town of Antigonish to such an amount as the Council deems necessary;

THAT the issue of debentures be postponed pursuant to Section 92 of the Municipal Government Act and that the Council borrow from time to time a sum or sums not exceeding four million dollars Dollars (\$ 4,000,000) in total from any chartered bank or trust company doing business in Nova Scotia;

THAT pursuant to Subsection 92(2) the sum be borrowed for a period not exceeding Twenty-Four (24) Months from the date of the approval of the Minister of Municipal Affairs and Housing of this resolution;

THAT the interest payable on the borrowing be paid at a rate to be agreed upon; and

THAT the amount borrowed be repaid from the proceeds of the debentures when sold.

THIS IS TO CERTIFY that the foregoing is a true copy of a resolution read and duly passed at a meeting of the Council of the Town of Antigonish held on the 17 day of March, 2025.

GIVEN under the hands of the Clerk and under the seal of the Town of Antigonish this 17 day of March, 2025.

Clerk

To: Town of Antigonish Council
Randy Delorey, Chief Administrative Officer

Submitted by: Kyle Meisner P.Eng., Director of Public Works

Date: Monday, March 17, 2025

Subject: Shared Trunks and Routes Approval Request

Public Works is seeking approval to submit the list of priority shared trunks and routes for consideration of provincial cost shared paving in fiscal 2025-2026. The provincial request is for a multi-year list of priority trunks and routes for repaving due tomorrow, March 18, 2025. Please note, the submission is made annually so future year priorities can be modified with future submissions to the province.

Based upon current road conditions and informal feedback shared by various councillors, the Department of Public Works recommends the following list of priorities to be approved by Council for submission to the province's Shared Trunks and Routes shared funding program.

Priority 1 (2025): Highway 7 (West Street) from Highway 4 to Highland Drive (0.61km)

Priority 2 (2026): Rt 245 (Hawthorne St) from Pleasant St to Pine St (0.60km)

Priority 3 (2027): Rt 245 (Hawthorne St) from Pine St to MacDougall St (0.59km)

Priority 4 (2028): Rt 337 (Main St) from Hawthorne St to College St (0.27km)

Recommended Motion:

That the Town of Antigonish submit the following list of priority road work to the Province of Nova Scotia as part of the provincial program for cost sharing maintenance of trunks and routes.

Priority 1 (2025): Highway 7 (West Street) from Highway 4 to Highland Drive (0.61km)

Priority 2 (2026): Route 245 (Hawthorne Street) from Pleasant Street to Pine Street (0.60km)

Priority 3 (2027): Route 245 (Hawthorne Street) from Pine Street to MacDougall Street (0.59km)

Priority 4 (2028): Route 337 (Main Street) from Hawthorne Street to College Street (0.27km)



The Nova Scotia Association of Garden Clubs (NSAGC) 2025 Annual Convention will be held at St. Francis Xavier University, Antigonish, NS on June 13th and 14th 2025.

NSAGC is the coordinating body of the 54 garden and horticultural societies from all areas of Nova Scotia. Its main objective is to promote the general landscape beautification of the Province of Nova Scotia and to encourage the formation of horticultural groups in seven districts: Cape Breton, Eastern, Central, Halifax, Valley, Western and South Shore. The Association became an entity in 1954 but can trace its origin to the appointment of the Rural Beautification Committee by Nova Scotia Agriculture Minister John MacDonald in 1944.

As the hosting region, clubs in the Eastern District (Pictou, Westville, St. Mary's, Antigonish & Lismore) are responsible for all aspects of the convention including fundraising and sponsorship. The program features prominent guest speakers, tours, workshops, vendor tables, plant sales, contests, awards banquet and the annual business meeting. Over 200 budding gardeners, amateurs and professionals alike, from Yarmouth to Northern Cape Breton will represent their respective clubs.

Our budget for hosting the Convention is approaching \$37,000 and it falls to the Eastern Region to raise that amount. Sponsorship has been an important part of the annual event and as Co-Chair of the Committee for 2025 I am seeking your financial support. At this point, I am suggesting that Platinum Sponsorship will be \$5,000 +, Gold Sponsorship will be \$1000 +, Silver \$500 +, and Bronze \$200 +. However, lesser amounts would be greatly appreciated and will be duly acknowledged. Sponsorship will be recognized throughout the Province of Nova Scotia. Please review the chart on the second page.

Cheques should be made payable to NSAGC2025 and mailed to: Attention: David Burrell, NSAGC 2025 Convention, 91 Birch Hill Lane, Caribou River, Nova Scotia B0K 1H0 or e-transferred to: convention@nsagc.com. (please put your name/business in the memo area of the e-transfer.)

Thank you for giving this matter your consideration!

Sincerely,

Mary Campbell for:

Denise Chisholm
Co-Chair, 2025 NSAGC Committee
902 890 7082

also - we are asking the 200 people attending to bring an item for the Food Bank to help our community. Anyone can attend, garden club member or not. People will be spending money in Antigonish shopping & eating.

2025 NSAGC Convention Budget

	Quantity	Price	Total
<u>Income</u>			
Registration	200	\$60.00	\$12,000.00
Banquet	200	\$50.00	\$10,000.00
Vendors	20	\$50.00	\$1,000.00
50/50 Tickets	800	\$5.00	\$4,000.00
Silent Auction	Est.		\$500.00
		Income Sub-Total	\$27,500.00 \$27,500.00
<u>Expenses</u>			
Food	Friday Night		\$2,440.38
	Saturday – Coffee & Tea	Est.	\$5.00 \$1,000.00
	Saturday AM Break		\$1,666.35
	Saturday Lunch		\$5,290.00
	Saturday PM Break		\$2,525.98
	Banquet		\$6,555.00
	Sub-Total		<u>\$19,477.71</u>
Venue	All of Second Floor – 2 Days		\$4,312.50
	Water Cooler Rental		\$69.35
	Media Services		\$1,859.55
	Security		\$82.80
	Emcee – Emily		\$241.11
	Sub-Total		<u>\$6,565.31</u>
Other	Early Registration Draw – 2 people		\$120.00
	Registration		\$500.00
	Printing		\$500.00
	Swag Bags	\$9.00 * 200	\$1,800.00
	Decorating		\$200.00
	50/50		\$40.00
	Bank Fees	\$18.00 * 12	\$216.00
	Speakers		\$5,322.36
	Contingency for Unknown Expenses		\$2,500.00
	Sub-Total		<u>\$11,198.36</u>
	Expense Sub-Total	\$37,241.38	\$37,241.38
	Net		<u>-\$9,741.38</u>

2025 NSAGC SPONSORSHIP OPPORTUNITIES



Plantinum \$5000 +	<ul style="list-style-type: none">• Invitation to speak at the 2025 NSAGC• Included in program, please provide pdf of logo• Logo on display• Flyer / business card /swag to be included in 200 registration bags
Gold \$1000 +	<ul style="list-style-type: none">• Included in program, please provide pdf of logo• Logo on display• Flyer / business card / swag to be included in 200 registration bags
Silver \$500 +	<ul style="list-style-type: none">• Included in program, please provide pdf of logo• Logo on display
Bronze \$200 +	<ul style="list-style-type: none">• Included in program, please provide pdf of logo



To whom it may concern:

We are writing to request that the municipal landmark _____ in the community of _____ be lit in purple to celebrate National Dental Hygienists Week™ (NDHW™) as part of the Canadian Dental Hygienists Association's national "Put Your Purple On!" campaign.

National Dental Hygienists Week™ is celebrated annually on April 4-10, highlighting the importance of maintaining good oral health practices while helping Canadians to understand the vital role those dental hygienists play in the health care system. Our theme "Oral Health for Total Health," reminds us that taking care of our mouth, teeth, and gums positively impacts other aspects of our lives.

Why purple? The colour purple is associated with dental hygiene and has been the official colour of dental professionals since 1897 when lilac was first chosen for the emblem of the National Association of Dental Faculties. Purple has long been the trim colour for dental hygiene graduates' caps and gowns and is said to signify compassion, purpose, and inspiration.

Last year, there were 103 Canadian landmarks lit in purple. Over the past several years, lightings have included: BC Place Stadium, The Bastion (Nanaimo), Science World (Vancouver), Calgary Tower, Edmonton High-Level Bridge, The Atlas Hotel (Regina), Manitoba Legislative Building (Winnipeg), CN Tower (Toronto), Niagara Falls, RBC Place London, Ottawa Sign, Montréal Olympic Park, Fredericton City Hall, Province House (Halifax), St. John's Convention Centre and more.

We'd like to give every community in Canada, and globally, the opportunity to share in our celebrations. Please let us know if you are interested in joining our "Put Your Purple On!" campaign this April. You may contact me at bsander@cdha.ca.

CDHA is the collective national voice of more than 31,000 dental hygienists in Canada, directly representing 22,000 individual members, including students. Since 1963, CDHA has worked to advance the profession and promote the importance of oral health. Dental hygiene is the sixth largest registered health profession in Canada with professionals working in a variety of settings, including independent dental hygiene practice, with people of all ages, addressing issues related to oral health. To learn more about NDHW visit cdha.ca/ndhw. For more information on oral health, visit dentalhygienecanada.ca.

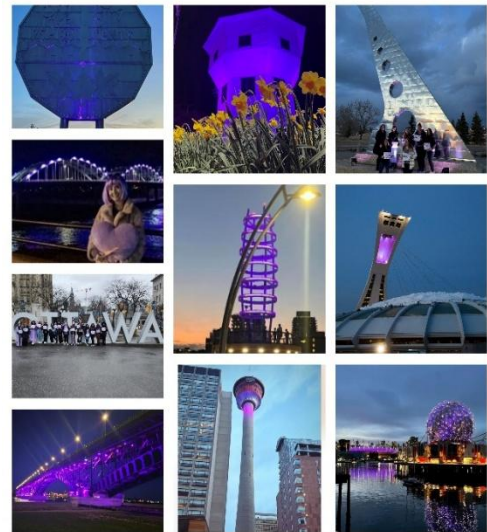

Regards,



Brittney Sander
Marketing & Communications Coordinator
Coordonnatrice du marketing et des communications
The Canadian Dental Hygienists Association
L'Association canadienne des hygiénistes dentaires
1122 Wellington St W, Ottawa, ON K1Y 2Y7
t: 613-224-5515 x147 • 1-800-267-5235
f/t: 613-224-7283
bsander@cdha.ca • www.cdha.ca



Subject: CAO Report
To: Antigonish Town Council
Date Prepared: 25-03-17
Prepared by: Randy Delorey, Chief Administrative Officer

Administration

This report compiles monthly updates and progress reports from the Town of Antigonish’s Administration, AREA Community Development, and Public Works departments.

Highlights

- Main focus of efforts has been planning and preparing for strategic planning process, Operations, AREA including Antigonish Solar Garden, and the RK.
- Strait-IT Board Meeting – Reviewed draft Technology Use Policy and Budget Items
- Town & County Joint Council Meeting
- Meetings with Stakeholders including County, CACL, StFX, AREA, RK
- Provided Antigonish Electric Utility inputs to the AREA Strategic Planning Consultants
- AREA Weekly meetings for Antigonish Solar Garden Updates
- AREA Board Meeting
- 2025-2029 Strategic Planning Process several council meeting presentations and workshops
- RK Steering Committee Meetings
- Council Advisory Committee Applications Coming in.
- An advocacy day in Halifax meeting with Senior Government Officials to discuss priority issues
- Arena Commission Meeting
- JOSH Committee Meetings
- HAF Planning Meeting with Consultants and County
- Strait Area Mayors, Wardens, and Chiefs meeting – reestablishing regular meetings

Strategic Initiatives Update:

Projects
Title: Net Zero Engagement Strategies Funding Opportunity - Sustainable Communities Challenge Fund administered by NSFM
Status Update: Continuation of engagement strategy work. Reviewing background material provided and discussing message building around current initiatives
Next Step: On-going
Title: Grid Modernization and New Substation
Status Update: Pole Line work has been completed. There is some live line work to be completed where the new circuit interconnects with NSPI poles. Quality and safety continue to be excellent with Connect Atlantic. Highway crossing to Nova Landing was completed. Easement requirements continue to be processed. Interconnection Amendment Agreement with NSPI has been completed. Substation assembly proposal still being evaluated. Pole top transformers replacements will resume in the Spring. Work on Tender Packages for Substation ground and foundation works to start soon. Grubbing work has commenced to clear and level the site.
Next Step: on-going

Title: FCM/SCCF – Community District Energy System (CDES) Feasibility Study
Status Update: Final report to SCCF has been accepted. Still waiting on final review from FCM
Next Step: WSP presentation to council scheduled for March’s regular council meeting.
Title: Green Municipal Fund – GHG Reduction Pathway Capital Project – Deep Energy Retrofits
Status Update: Full Application has been received
Next Step: Completion and submission to be determined
Title: Green and Inclusive Community Buildings
Status Update: Funding application for Low Carbon Resilience Retrofit has been submitted to Housing, Infrastructure and Communities Canada (HICC) for approval
Next Step: Awaiting response from HICC
Title: Provincial Growth and Renewal for Infrastructure Development Program (GRID)
Status Update: Application was successful and funding to be awarded.
Next Step: on-going
Title:
Status Update:
Next Step:
Title:
Status Update:
Next Step:
Title:
Status Update:
Next Step:

AREA Update:

Projects
Title: HOME Program Review
Status Update: Meeting with Mahone Bay and Berwick to discuss potential funding opportunities through FCM.
Next Step: Details to be shared at a later date
Title:
Status Update:
Next Step:
Title:
Status Update:
Next Step:
Title:
Status Update:
Next Step:
Title:

Status Update:
Next Step:
Title:
Status Update:
Next Step:

Subject: Staff Report
To: Antigonish Town Council
Date Prepared: Mar 12th, 2025
Prepared by: Kyle Meisner, P. Eng., Director of Public Works

Department of Public Works

Projects/Tender Update:

Projects
Title: STP Desludging
Status Update: Project Completed Jan 18 th
Next Step: Final Invoices Received; Project Completed
Title: STP Screening Design RFP
Status Update: RFP closed Feb 19 th
Next Step: Contract awarded to CBCL for design
Title: Bay St Municipal Servicing Upgrades
Status Update: Project Funding Applications and Budget
Next Step Design work in progress with WSP. Design at approx. 95% ICIP Funding Received for \$1.8M GRID Funding Received for \$1.1M – Feb 20 th ATF Funding Application - \$0.55M – Pending Approval
Title: Hwy4 AT/Roundabout Project
Status Update: Ongoing follow-ups with NSDPW on the phased project
Next Step: NSDPW working with Strum to finalize design for project. Project expected to go to tender in early spring.
Title: Safety Management System
Status Update: Drafting of Programs underway
Next Step: Meet with CCS (consultant) and proceed with completion of SMS
Title: Safety Audits
Status Update: Organization-wide Safety Audits underway with CCS
Next Step: Planning and implementation of recommendations with JOHS committee

Electric Utility (EU):

Projects
Title: Electric Utility Capital Modifications
Status Update: EU working group continues to assess project scheduling & major stock purchases/delivery Substation Site work preparation continues. Preparations and assessments underway for 2025 construction season
Next Steps:
Title: Solar Garden and BRBB Pole line for Solar Garden
Status Update: Site testing generally completed. Solar Garden currently hooked to grid and producing power during testing phase. Inspection completed for Deviation work Feb 4 th 2025 Substantial completion under assessment. Facility OM being assessed for requirements.
Next Step: Project follow-ups in progress.
Title: EU Code of Practise

Status Update: Development of Rubber Glove Code of Practice is restarting with M Smith and CCS Safety
Next Step: Format and update Code of Practice for submission.
Title: Power Outages
Status Update: Feb 15 th – Minor outage for Braemore Sub (Blown Pole Fuse) For maintenance work - short service outages will be required till Code of Practice in place.
Next Step: Complete Code of Practise with CCS and M. Smith
Title: Operations Items
Status Update: Items as noted below
Next Step: Street lights - replacement work continues Pole Line Work – ongoing Service Work - ongoing Tree trimming work continues. Electrical Inspections Ongoing Meter reading
Title: Pad Mount transformers (Xfmrs)
Status Update: Finalized quotes for Capital Purchases (growth and stock)
Next Step: Pad Mount Transformers ordered Feb 28 th
Title: Worker off due to lost time incident Jan 29 th 2025
Status Update: Worker returned to work part-time with restrictions Feb 10th
Next Step: Worker back to full-time work March 12th Complete investigation into causes of incident.

Treatment Facilities:

Projects
Title: Treatment Facilities Manager Job Posting
Status Update: Interviews for position completed; review and recommendations underway
Next Step: Position awarded to J. Jackman, transition plan in place starting with promotion to Foreman until new staff trained to take on-call duties
Title: Treatment Operator New Hire #1
Status Update: Operator selected based on competitive process
Next Step: Job offer accepted by candidate, start date March 10th
Title: Treatment Operator New Hire #2
Status Update: Operator selected based on competitive process
Next Step: Job offer accepted by candidate, start date March 31st
Title: Operational Support (Contract)
Status Update: Offer received for temporary contract assistance through transitional period
Next Step: Company to assess TOA needs for short term additional staffing
Title: Source Water Review
Status Update: Prepping RFP for negotiation services to secure test well locations
Next Steps: Release RFP for bidding
Title: Water Utility Items
Status Update: James River Dam - Fall inspection completed. Report received Jan 30th
Next Step: Awaiting invoice. Follow-ups to report to be undertaken in spring.
Title: Sewage Plant Aeration Work
Status Update: Work on hold due to lack of staff
Next Steps: Continue to clear aerators of debris / rags
Title: Sewer Plant Chemical Desludging
Status Update: Project underway to add chemical desludging agent to clean up any leftover material
Next Step: Continue for prescribed 120-day period

Public Works (PW):

Projects	
Title:	PW Manager Position
Status Update:	The position has been filled. G. Gillis started in the role on Feb 24, 2025.
Next Step:	n/a
Title:	PW Equipment Operator Hiring
Status Update:	A second temporary operator has been awarded a position and is scheduled to begin March 6, 2025.
Next Steps:	Onboarding and assessments to continue in March for new and recent hires.
Title:	Worker off due to lost time incident, Jan 18, 2025.
Status Update:	Worker had returned to work (Feb 3rd), but is now off for 3-month leave for other medical issue. Incident investigation has been completed and presented to the JOSHC.
Next Steps:	Recommendations from the investigation are under review and action assigned to appropriate persons.
Title:	Seasonal/Street Operations
Status Update:	Plowing and salting operations on going as needed with no major events in February. Work on potholes continues.
Next Step:	Ongoing operations throughout March. Large pothole repairs scheduled for first week of March.
Title:	Water Breaks
Status Update:	Feb 5 - 42 West Street (4" line) Feb 5 - West Street at Highland Drive (4" line) Feb 21 - Vincent Way (12" line) Feb 21 - Landsdown Drive at Scarboro Drive (6" line) Feb 27 - Xavier Drive at Margaree Street (6" line) Mar 4 - St. Ninian Street at Cathedral (8" line)
Next Step:	Crews continue to respond and repair as needed.
Title:	Municipal Servicing Permits
Status Update:	Feb 7 th – 106 College St Demolition Feb 7 th – 108 College St Demolition
Next Step:	Permits and inspections continue as per policy
Carryover	
Title:	Sewer Camera Investigations
Status Update:	Project halted due to camera lost on James Street due to pipe failure (dug Jan 17th)
Next Step:	Reline of replace sewer main on James Street (capital budget)
Title:	PWD Equipment
Status Update:	Equipment assessments underway for capital budgets
Next Step:	Determine priority and cost for replacements
Title:	Main Line/Water Valves
Status Update:	Assessment of operational status continues
Next Step:	Cap old 4" main on West Street in the Spring. Replace Valves as necessary to restore control over area.

Waste Management:

Projects
Title: Circular Update
Status Update: Offer made by Circular, not sufficient to cover TOA budget
Next Step: Turn over recycling pickup to Circular
Title: Solid Waste Items
Status Update: Waste Management Bylaw - awaiting Municipal Affairs approval for SOTs
Next steps:
Title: Waste disposal weights – End of Feb, 2025
Status Update: RWC (Feb) 928.18 T ICI (Dec) 2253.31 T



Kyle Meisner, P.Eng.
Director of Public Works

Subject: CAO Report
To: Antigonish Town Council
Date Prepared: March 13, 2025
Prepared by: Shannon Long, Acting Director of Community Development

Community Development

Strategic & Capital Projects of Council:

Projects
Active Transportation Corridor
Status Update: Planning for AT Trail Town Hall
Next Step: The Town Hall event regarding the AT Project as requested by Council during the Special Council meeting held on January 9 has been scheduled for Tuesday, March 25 at the Regional in the AV auditorium. There were be a presentation followed by a question and answer session. A mailer has been sent to be printer and it will be sent out via Canada Post to all residents. The information has been added to the Town’s website, there will be social media posts, as well as radio ads
Sandlot Baseball Field Accessible Pathway
Status Update: Pathway Paved
Next Step: The pathway has been paved. Due to the lateness in the year, the landscaping is going to take place in the spring. Dexter will return to do the topsoil and hydroseed. In the meantime, hay has been placed down to cover the area around the pathway.
Accessible Pathway Connector Trail
Next Step: The Accessible Pathway Connector Trail is a paved pathway from the bottom of the accessible pathway that was paved in the Fall that goes the length of the turf field to the main entrance of the turf field. The Town has secured \$12,000 from the Youth Innovation Component for Enabling Accessibility Fund and another \$50,000 from the Province of Nova Scotia for this project.
Tourism
Status Update: Marketing Levy
Next Step: The Antigonish Tourism Advisory Committee continues to work with Mary Tulle on the hiring of a Tourism Officer. The Town is looking to enter into a partnership agreement with the Antigonish Tourism Association that would see the levy money sent to them annually. As of March 12 Town's Marketing Levy account has a balance of \$64,235.51.
Arbor Drive Playground
Status Update: Completed
Next Step: Additional Playground upgrades to other Town facilities will be recommended for Council consideration at budget time.
Parking Meter Renewal
Status Update: Completed
Next Step: Additional parking meter replacements will be recommended for Council consideration at budget time.
Accessibility
Status Update: Public Engagement
Next Step: Staff are expecting a draft of the review of the Accessibility Plan by March 17. Staff, along with the Accessibility Committee will have until Friday, March 21 to submit feedback back to the consultants. A special council meeting is tentatively scheduled for Wednesday, March 26 for council to approve the review.

Mini-Pitch
Status Update: Construction complete
Next Step: The Town and County are looking at splitting the cost of an accessible picnic table for the mini-pitch grounds.

Operational Projects:

Project
Advisory Committee Vacancies
The committee pages on the Town’s website continue to get updated and social media posts are currently advertising for community members to apply to be on a committee.
Alert System
Staff have been in touch with the newly formed NS Department of Emergency Management in regard to a new alert app and the possibility of the Town being one of the test communities of the app. Staff spoke to the Department on early February and will touch base again in a few months as they get closer to a launch date.
Beautification
Budget planning for 2025-26 Beautification Projects are underway including a new mural, new trees, new benches, and more garage cans. Councillor Murray is reaching out to the vendors to place the flower orders for the hanging baskets, bridge baskets, and planters.
Town Hall Lighting
A set list of colour presets for the five lights on the clock tower have been programmed. Staff will now be able to change the colours for holidays and special requests.
Town & StFX Partnership
Town and StFX staff attended a Police and License Committee meeting on Tuesday, March 4 where St. Patrick’s Day and Homecoming were discussed. By-Law has sent an email to our landlords mailing list reminding them of our Noise Control and Nuisance Party By-Laws.
Programming
<ul style="list-style-type: none"> Multi-Sport has 61 kids in this year’s program. The children have completed baseball/softball, tae kwon do, hockey, track and field, swimming, basketball, and gymnastics. The program didn’t have activities over March break but golf is due to start the week of March 16th. The Kids on the Move initiative that sees kids walk to school from the Farmers Market continues once a month with an average of 20 kids participating. The Older Adult Moving and Mingling program continues to be extremely success. The program ends on March 31. The Town’s Open Gym program normally ends at the end of March but this year, staff are looking to extend them until the end of May. This is open gym time with equipment at the St. Andrew Junior School from 9 to 11 a.m.
Pumper/Tanker RFQ
The pre-construction meeting has been scheduled with Fort Gary Fire Trucks and will take place February 25.
Community Equity & Anti-Racism Plan
The Antigonish Equity, Anti-Hate, Anti-Racism Plan is a shared document with the County that has to be approved by council and submitted to the province by April 1. A special council meeting is tentatively scheduled for Wednesday, March 26 for council to approve the plan. It will be sent to council in advance for review.
Community Grants
Applications for Community Grants has now closed. The information is being gathered to present to council.
Parking Enforcement
Letters were sent out on March 12 to individuals with parking tickets payments past due by 60 days totaling in \$6,337.

By-law, Policy & Procedures:

- Body Armour Policy (being developed)
- Live Streaming Policy (being researched)

By-Law Enforcement Statistics:

Reporting Period: February 12 to March 13, 2025

Parking Tickets

247 Tickets Issued

(inclusive of Town, StFX and St. Martha's)

By-Law Office General Breakdown of New Files During Reporting Period:

February 12 to March 13, 2025

Case Files by Investigation Type

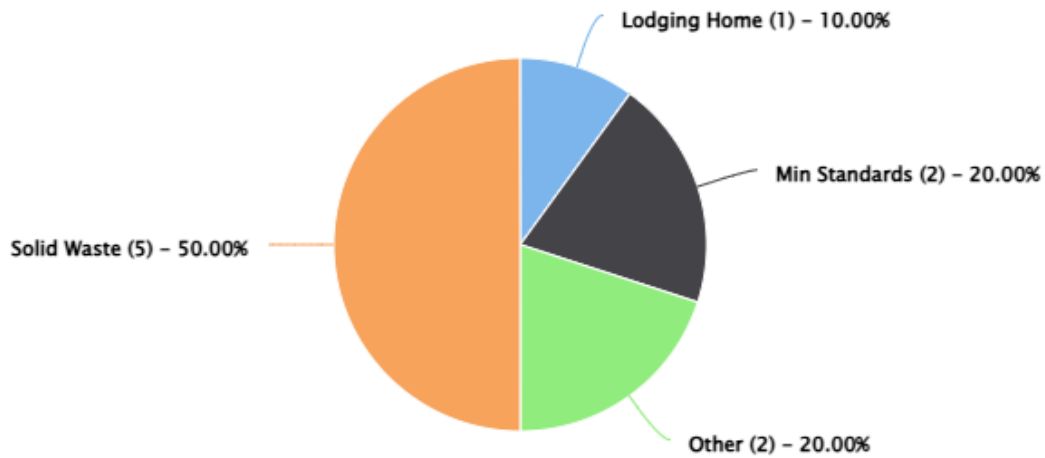

Subject: CAO Report
To: Antigonish Town Council
Date Prepared: March 12, 2025
Prepared by: Meaghan Barkhouse, Director of Corporate Services

Corporate Services

Highlights

On March 4th, the Director presented a Q3 financial update to the Committee of the Whole, and the Audit Committee community member. This presentation included additional information on how the current budget is structured, the account code structure and how it ties into provincial reporting requirements (Financial Indicators Report – FIR). This was to provide additional information to help during the upcoming budgeting process. The 2024-25 fiscal year end projections were included for discussion, including the operating surplus expectation on March 31, 2025 and the projected operating and capital reserve balances. The Director used the provincial guidelines on what is considered high-, medium-, and low- risk reserve balance compared to expenses.

The CAO, Town legal counsel and the Director of Corporate Services have been working this month on a proposal for the I.B.E.W., Local 1928 (IBEW) collective bargaining that is to take place on March 19th and 20th. The Electric Utility contract will be negotiated first with Public Works and Treatment Facilities to follow, as requested by the union to accommodate schedules. As stated previously, the Director intends to conduct negotiations in a manner similar to the previous round, which successfully resulted in two agreements within two days. The Town has maintained a positive and respectful working relationship with the IBEW over the past four years and remains committed to fostering this collaborative approach throughout the upcoming negotiations.

The Director has been collaborating with the CAO and other Town Directors to align strategic priorities. This includes key priorities for the Corporate Services department, but also to identify how it can best support other departments. As a key support function within the Town, Corporate Services plays a vital role in understanding departmental priorities and ensuring they have the necessary resources to achieve their goals. The sharing of these priorities was in the March 11th workshop with Council. Corporate Services is excited to learn more about Council’s priorities as she begins her preliminary budget preparations.

Department Update:

Projects
Title: 2024-25 Year-end Projections
Status Update: Director presented year-end projections to the Committee of the Whole on March 4 th , 2025.
Next Step: Completed
Title: Audit Service Request for Proposal
Status Update: Corporate Services received three proposals for a five (5) year audit service contract. This request for proposal (RFP) was posted on both the Town of Antigonish website and the NS Procurement Portal. After carefully reviewing the proposals, with evaluation criteria that was included in the original RFP, Corporate Services is recommending that Council appoint MNP, LLP (MNP) to be the Town of Antigonish’s Auditor for fiscal years: 2024-25, 2025-26, 2026-27, 2027-28 and 2028-29. MNP was the previous Auditor.
Next Step: Council appoints recommended auditor

Title: Tax Sale Process

Status Update: In process of notifying the property owners that their properties are eligible for tax sale and have Council approval to be put up for tax sale if their arrears are not paid in full or they enter a payment arrangement contract.

Next Step: Start next steps as per our Tax Collection Policy once given direction from Council.

Title: Human Resources

Employee Hiring and Attrition

- J. Jackman has accepted the position of Manager of Treatment Facilities. Her start date will be determined when the Treatment Facilities division is at full complement, with new employees trained and approved for on-call duties. Estimated timeline: end of May
- J. Jackman has been promoted to Water/Wastewater Foreman – Temporary until her start date as Manager of Treatment Facilities. This promotion is due to the vacancy in the Manager position.
- T. Kasza has accepted the position of Water/Wastewater Operator, his start date was March 10.
- E. Mattie has accepted the position of Water/Wastewater Operator, with an anticipated start date of March 31.
- G. Smith has rescinded his acceptance the position of Water/Wastewater Operator.
- G. Gillis has accepted the position of Manager of Public Works, her start date was February 24.
- J. Rowe has accepted the position of Equipment Operator/Labourer temporary 3 months, with a possible extension of up to 6 months

Employment Opportunities:

- Summer Recreation Intern: Administrative Assistant – application deadline is March 14
- Parks and Recreation Maintenance Crew Members – application deadline is March 14
- Parks Maintenance Crew Members – application deadline is March 14
- Manager of Parks and Recreation position will be posted this month

External Human Resource Support

- Corporate Services reached out to multiple firms that provide human resource consultation and support. Four firms provided quotes on the stated expectations, with a focus on recruitment and onboarding. They are taking the lead on the seasonal recreation employee that is ongoing, as well as reviewing the layout and effectiveness on current job descriptions, looking to standard how they are presented.

Next Step: On-going

Title: Safety Update

Corporate Services will be working with all Town Hall employees who are on the Joint Occupational Health and Safety Committee (JOHSC) to make recommendations on how to address the deficiencies that were identified by CC Safety and Compliance. Two updates have been completed:

- Electrical room is locked, proper signage is on order
- Three (3) step-stools/ladders (with an evaluation of 3 or residential use only) were taken out of commission and will be replaced with the appropriate grade ladder (Grade 1 or 2).

Next Step: On-going

Title: Equity, Diversity, and Inclusion in the Workplace

Status Update:

This project was on temporary pause, the Director of Corporate Service is in progress of re-connecting to our consultants to have the report presented to Council.

Developing and implanting an Equity, Diversity, and Inclusion (EDI) policy in the workplace is one of the accords Council signed with when the Town began applying for funding related to the grid modernization

funding. The Directors of Corporate Services and Community Development, and the Strategic Projects Coordinator have received a working draft of the consultant’s report on EDI for Town of Antigonish, which has come with recommendations and steps to make improvements within the workplace. This is being reviewed for comment and will be presented to Council over the coming month.

Next Step: Consultants Report to be presented

Title: Work from Home Policy

Status Update: Corporate Services has finalized a draft Work from Home (WFH) policy that is ready for internal review. It has included potential strategies that other similar Town municipalities have implemented, including the Town of Bridgewater.

Next Step: Finalize and present to Council regarding a Work from Home Policy.

Title: In Development: Charitable Donation Policy

Status Update: Corporate Services has prepared a charitable donation policy for the Town of Antigonish. This would formalize the charitable donation receipt program and outline the standards for evaluating donations in accordance with Canadian Revenue Agency (CRA) guidelines. This is in the review stage.

Next Step: Finalize and prepare a memo to Council regarding a Charitable Donation Policy.

Council Grants to Organization Account:

Budget: \$199,044.39 Committed (YTD): \$189,012.57 Remainder: \$10,031.82

Electric Utility - Statement of Operations
For the Eleven Months Ending Friday, February 28, 2025

	2024		2023	
	Budget	Actual	YTD	March 31st
Revenue				
Operating				
Electric Revenue	15,772,416	13,621,581	12,110,248	13,797,126
Expenditure				
Operating				
Power Purchases	7,701,260	8,151,297	9,586,958	10,470,907
Power Generation and Delivery	5,199,413	2,128,676	1,951,536	2,229,631
Electrical Buildings/Subs	17,977	29,533	10,238	10,725
Electric Distribution Exps	241,782	292,554	1,045,318	236,987
Property Taxes	2,666	2,745	2,588	2,588
Depreciation	319,524			256,291
Admin - Common Services	1,412,268	984,255	887,303	1,196,890
Interest and Bank Charges	6,013	13,008	11,676	12,930
Wages	619,500	555,169	596,298	504,475
	<u>15,520,403</u>	<u>12,157,237</u>	<u>14,091,915</u>	<u>14,921,424</u>
Non-operating revenue				
Interest on investments				
Interest on Accounts	20,000	23,827	15,760	(1,469)
	<u>20,000</u>	<u>23,827</u>	<u>15,760</u>	<u>(1,469)</u>
Non-operating expenditures				
Debt Payments				
Transfers to other funds				575,000
	<u>305,572</u>			<u>575,000</u>
Excess(deficiency) of revenue over expenditure	(33,558)	1,488,171	(1,965,907)	(1,700,767)

Water Utility - Statement of Operations
For the Eleven Months Ending Friday, February 28, 2025

	2024		2023	
	Budget	Actual	YTD	March 31st
Operating Revenue				
Water Revenue	\$1,725,522	\$1,379,068	\$1,151,043	\$1,482,715
Fire Protection	376,036	376,036	286,172	286,172
Fire Protection - County	293,085	293,085	188,679	188,679
Other Water revenue	2,000	3,001	12,536	13,036
	<u>2,396,643</u>	<u>2,051,190</u>	<u>1,638,430</u>	<u>1,970,602</u>
Operating Expenditure				
Property Taxes	40,415	40,242	39,085	39,085
Depreciation	537,500			397,511
Source of Supply	37,226	18,831	33,476	35,750
Purification	349,189	346,110	272,402	326,705
Power and Pumping	47,912	42,364	42,745	47,033
Transmission and distribution	133,360	158,896	104,320	112,475
Administration	100,605	115,030	91,202	105,166
Supervision	644,031	590,361	549,943	599,937
Wages	180,161	158,084	173,500	187,604
	<u>2,070,399</u>	<u>1,469,918</u>	<u>1,306,673</u>	<u>1,851,266</u>
Operating Profit	326,244	581,273	331,755	119,335
Non-operating revenue				
Interest on investments				
Interest on Accounts		5,212	4,638	5,086
Misc Non-operating Revenue				
		<u>5,212</u>	<u>4,638</u>	<u>5,086</u>
Non operating expenditure				
Debt Payments	325,912	163,425	164,138	166,841
Transfers to other funds				
	<u>325,912</u>	<u>163,425</u>	<u>164,138</u>	<u>166,841</u>
Excess(deficiency) of rev over exp	332	423,060	172,255	-42,421

**Council Report
General Fund**

For the Eleven Months Ending 2/28/2025

	2024	2024	2023	2023	Remaining
	Budget	Actual	Budget	Actual	Budget
Revenue					
Taxes	7,931,983	7,988,311	7,501,015	7,269,304	(56,329)
Grants in Lieu of Taxes	1,206,255	65,296	1,109,615	62,265	1,140,959
Sale of Services	1,058,889	798,084	949,423	711,914	260,805
Services provided to other governments	397,903	141,278	302,535	165,955	256,625
Other revenue from own sources	137,095	470,642	143,000	461,066	(333,547)
Unconditional Transfers from other governments	204,039	172,126	478,844	90,481	31,913
Other Transfers	2,125,770	385,400	2,142,198	3,000	1,740,370
	13,061,933	10,021,137	12,626,630	8,763,985	3,040,796
Expenditure					
Mayor and Council	460,844	429,457	435,050	389,268	31,387
Corporate Services and Office of the CAO	3,446,586	765,774	2,756,302	839,944	2,680,812
Engineering and Public Works	1,462,376	1,263,873	1,493,387	1,452,860	198,502
Environmental Health Services	1,353,886	1,260,748	1,391,966	1,147,712	93,139
Community Development Administration	479,479	432,153	399,059	403,457	47,325
Partnerships & Initiatives	499,701	1,224,520	564,330	744,218	(724,819)
Protective Services	2,960,477	2,650,359	2,997,244	2,109,349	310,118
Recreation and Cultural Services	706,221	584,373	728,692	576,010	121,848
Provincial Responsibilities	1,692,329	1,554,536	1,760,578	1,529,826	137,792
	13,061,899	10,165,795	12,526,607	9,192,643	2,896,105
Excess(deficiency) of revenue over expenditure	34	(144,657)	100,023	(428,658)	144,692