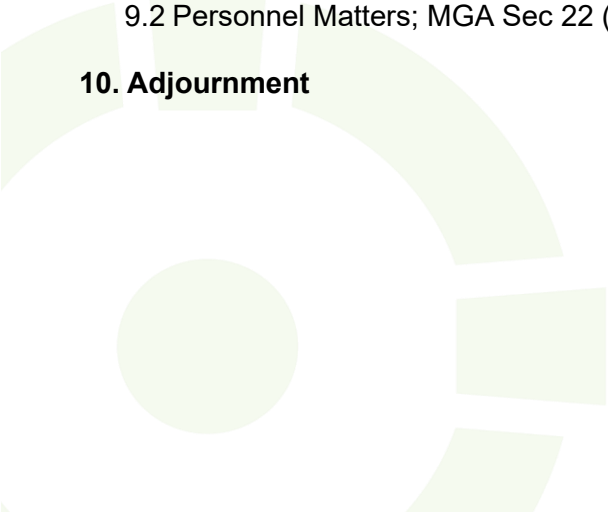

MEETING: Regular Town Council Meeting
DATE: September 15, 2025
TIME: 6:00 PM
PLACE: Town Council Chambers

Agenda

- 1. Call to Order & Land Acknowledgement**
 - 2. Approval of Agenda**
 - 3. Acceptance of Minutes**
 - 3.1 Minutes of the Regular Council Meeting – August 18, 2025
 - 3.2 Minutes of the Special Council Meeting – September 2, 2025
 - 4. Presentations/Proclamations/Flag Requests**
 - 4.1 Certificate of Appreciation – Oona Landry
 - 4.2 Cadets Day – Flag Request
 - 4.3 National Day for Truth and Reconciliation – Flag Request
 - 5. Business from Committee of the Whole**
 - 5.1 Capital Projects – Bay Street & West Street
 - 6. Business from the Minutes**
 - 6.1 Water & Sewer Update
 - 7. Correspondence/Sponsorships**
 - 7.1 Pictou-Antigonish Regional Library -Annual Report
 - 7.2 National Day of Truth and Reconciliation – Concert – Request for Financial Support
 - 7.3 GenWell - Human Connection Movement Workshop – Request for Financial Support
 - 7.4 2025 Paqtnekek Traditional Powwow (Information Only)
 - 8. Staff Reports**
 - 9. In-Camera**
 - 9.1 Contract negotiations; MGA Sec 22 (2) (e)
 - 9.2 Personnel Matters; MGA Sec 22 (2) (c)
 - 10. Adjournment**
- 

DRAFT

**Regular Council Meeting
August 18, 2025
Town Council Chambers**

Present

Mayor S. Cameron
Deputy Mayor D. Roberts
Councillor L. MacLellan
Councillor A. Murray
Councillor J. Pelly
Councillor J. Sullivan

Regrets

Councillor, P. McKenna

Also in Attendance

R. Delorey, CAO
M. Fougere, Deputy Clerk
M. Barkhouse, Director of Corporate Services
S. Long, Director of Community Development
K. Meisner, P. Eng., Director of Infrastructure and Engineering
M. Williams, Marketing and Communications Officer

Media

Members of the Gallery

1. Call to Order & Land Acknowledgement

Mayor S. Cameron called the meeting to order at 6:01 PM and acknowledged that the meeting took place in the traditional and ancestral territory of the Mi'kmaq people and recognized that we are all treaty people.

2. Approval of Agenda

Moved: Councillor Pelly

Seconded: Deputy Diane Roberts

Motion: To approve the Agenda as presented.

Motion Carried

3. Acceptance of the Minutes

3.1 Minutes of the Regular Council Meeting – June 16, 2025

3.2 Minutes of the Special Council Meeting – July 25, 2025

3.3 Minutes of the Special Council meeting – August 5, 2025

The minutes of the Regular Council Meeting of June 16, 2025, and the Special Council Meetings of July 25, 2025, and August 5, 2025, were accepted as presented.

4. Presentations

4.1 Stephen Jewkes – Proposed Changes to the Creighton Lane Parking Lot

Mr. Jewkes appeared before Council to present concerns regarding proposed changes to the Creighton Lane parking lot behind his business. He expressed opposition to converting existing free parking to paid parking, noting the lot currently functions well with

a mix of free and paid spaces. He circulated photos of the lot and nearby free parking at St. Mary's Street and referenced examples from other communities that adopted free downtown parking to support local businesses. He emphasized that the existing balance supports both turnover and accessibility and requested that the current arrangement be maintained.

During the question-and-answer period, Council discussed the potential impacts of parking changes, including turnover, employee and student use of free spaces, cost implications of kiosks, and possible effects on local businesses compared to the mall, which does not charge for parking. It was noted that parking meters are intended to support turnover rather than generate revenue, and that future growth and densification may increase parking pressures.

The Mayor thanked Mr. Jewkes for his presentation.

5. Business from Committee of the Whole

5.1 Beautification Committee – Member Recognition

Councillor Murray, Chair of the Beautification Committee, brought forward a motion to formally recognize a community member for over 30 years of volunteer contributions to the Town.

Moved: Councillor Murray

Seconded: Councillor MacLellan

Motion: That Oona Laundry be formally recognized for her outstanding volunteer contributions with a certificate of appreciation in gratitude for her lasting impact on the Town of Antigonish.

Motion Carried

5.2 Settlement in Antigonish for Families Everywhere (SAFE) – Funding Request

At the Committee of the Whole meeting held on August 5, 2025, representatives from SAFE (Settlement in Antigonish for Families Everywhere) made a presentation regarding a funding request.

Moved: Councillor MacLellan

Seconded: Councillor Murray

Motion: That Council approve a one-time donation in the amount of \$6,000 to the Settlement in Antigonish for Families Everywhere (SAFE), to be allocated from Council's discretionary fund.

Motion Carried

5.3 Creighton Lane Parking

At 6:30 p.m., the Mayor declared a conflict of interest and left the Chair. The Deputy Mayor assumed the Chair.

The CAO provided context, noting this matter was referred from the Committee of the Whole for Council's decision. Options included:

Option 1: All potential parking spaces (~120 total) designated as paid parking once the new kiosk system is installed and operational.

Option 2: Only previously metered parking spaces (~59 total) designated as paid parking once the kiosk system is operational.

Option 3: Previously metered plus a portion of unmetered spaces (~95 total) designated as paid parking, while maintaining 24–25 free spaces on private property.

Option 4: Zero enforcement.

A deferral was also identified as a possible approach.
Discussions took place.

Motion 1

Moved: Councillor Murray

Seconded: Councillor Sullivan

Motion: That the Creighton Lane Parking Lot be not metered and free for all.

Discussion:

Council discussed parking enforcement, declining parking revenues, potential impacts on turnover and monitoring, and the need for balance between free and paid parking. It was noted that the Community Development Team is undertaking a broader review and will bring recommendations forward in the fall.

Motion Defeated

Motion 2

Moved: Councillor MacLellan

Seconded: Councillor Pelly

Motion: That Council maintain the status quo for Creighton Lane parking, with the horseshoe area remaining free and the inside lot remaining paid parking, and that a parking study be undertaken.

Discussion:

Council highlighted the importance of completing the study before committing to further investment and emphasized clarity around enforcement of the current parking arrangement as status quo.

Motion Carried

The Mayor resumed the Chair.

Council recessed at 6:50 p.m.

5.4 Temporary Borrowing Resolution - Public Works Equipment

M. Barkhouse provided a correction in her circulated memo, clarifying that the equipment is a Komatsu WA320-8, a four-wheeled, mid-sized wheel loader (not an eight-wheel loader as previously noted).

Moved: Councillor MacLellan

Seconded: Councillor Pelly

Motion: That Council approve the Temporary Borrowing Resolution in the amount of \$425,000.00 for the Public Works Equipment, specifically the front-end Loader.

Motion Carried

5.5 Resolution for Debenture – Solar Garden

A memo regarding the Solar Garden debenture was circulated in Council's package. The Mayor provided background, noting that this process differs from usual borrowing, as the Town only accesses debenture funding twice per year. A temporary borrowing has already been approved, and this resolution allows the Town to proceed with the debenture application.

Moved: Councillor MacLellan

Second: Councillor Murray

Motion: That a "Resolution for Pre-Approval of Debenture Issuance Subject to Interest Rate in the amount of \$4,000,000, for the Solar Garden, for a term not to exceed 20 years."

Motion Carried

5.6 Resolution for Debenture – Public Works Equipment

CAO provided context, Council approved the temporary borrowing so we can move forward on the purchase. These debentures are for long term borrowing and only available twice a year.

Moved: MacLellan

Seconded: Deputy Mayor Roberts

Motion: That a "Resolution for Pre-Approval of Debenture Issuance Subject to Interest Rate in the amount of \$425,000, for the front-end Loader (Public Works), for a term not to exceed 5 years."

Motion Carried

6. [Business from the Minutes](#)

6.1 Terry Fox Ride for Hope – July 8 Council Event

Council hosted a meal for the Terry Fox Ride for Hope event on July 8th. The Mayor provided background, noting that while informal discussions had occurred, no budget had been set in advance.

Moved: Deputy Mayor Roberts

Seconded: Councillor MacLellan

Motion: That Council approve the reimbursement of Councillors' expenses up to \$300 associated with preparing the meal for the Terry Fox Riders.

Motion Carried

7. New Business

7.1 Public Works Collective Agreement

Information regarding the proposed agreement was included in Council's package. The CAO provided background on the amendments.

Moved: Councillor Pelly

Seconded: Deputy Mayor Roberts

Motion: That Council Approve the proposed amendments to the Collective Bargaining Agreement between the Town of Antigonish and the International Brotherhood of Electrical Workers (IBEW) Local 1928 (Public Works and Facilities) for the term April 1, 2025, to March 31, 2029.

Motion Carried

7.2 Committee Nominations

(a) Police Advisory Board – 2 Vacancies

At 7:11 p.m., the Mayor stepped down as Chair and the Deputy Mayor assumed the Chair, as the Mayor would have a conflict of interest being the Chair of the Nominations Committee, which provided the recommendations to Council.

Motion: That Council appoint Hayden Fougere to the Police Advisory Board effective August 18, 2025, for a term ending October 21, 2028.

Result: Acclaimed

Motion: That Council reappoint Matthew Whitehead to the Police Advisory Board for a one-year term ending August 31, 2026.

Result: Acclaimed

(b) Arena Board – 1 Vacancy

Motion: That Council appoint Donnie MacInnis to the Arena Board, for three-year term ending April 2028

Result: Acclaimed

7.3 Sister town/city to Bethlehem

The Mayor circulated an email to Council and provided background on the proposal. David MacGillivray from Wood Gundy, also a Knight of Malta, visited the Holy Land and suggested establishing a sister-town relationship with Bethlehem.

Council discussed the proposal, noting concerns about the size difference between the communities and the potential benefit of partnering with a town within the same province. The Mayor highlighted potential public benefits, including connections through the diocese, the Cathedral, and STFX, and recommended referring the matter to staff for further review.

Council supported staff researching potential advantages and preparing a report for a future Committee of the Whole meeting, to be brought forward to Regular Council. Members expressed interest in exploring the concept further.

7.3 Fall Fair - Water shortage restrictions

The Mayor provided an update regarding the ongoing water ban. STFX has closed its pool due to limitations on the Town's water system.

Council was advised that with the upcoming Exhibition, live livestock will require water for washing. This item was presented for information purposes only. The Mayor noted that if a tanker system is used to supply water to the Exhibition, a funding request may be brought forward to Council at a later date. Staff will liaise with the Exhibition Committee to ensure Council is aware of arrangements in advance.

8. Correspondence

8.1 Knowledge Seekers Summer Scholars Camp – Letter of Support

Council was advised that a letter of support was circulated on July 17, 2025. A donation of \$500.00 was issued to this group.

8.2 2025 Nova Scotia 55+ Games - September 20-24, 2025

Council acknowledged the upcoming Games and extended best wishes to participants.

9. Staff Reports

The CAO provided updates on operational matters, including sewer and water systems, public works, and community programs:

Sewer System: Staff completed the re-circulation system. Odor has partially stabilized, though oxygen levels remain below target. A blower is being refurbished, and an RFP for a front-end piece has been posted, pending geotechnical design.

Water System: Residents' conservation efforts have resulted in an approximate 40% reduction in water usage. Reservoir drawdown has been reduced through staff monitoring and collaboration with the Department of Environment. REMO continues to be consulted for worst-case scenario planning.

Council Discussion & other Updates: Council raised topics including provincial support for drinking water in emergencies, propane fire pit safety during fire bans, public education on water conservation, and requested daily updates on water levels.

Additional updates included:

Multi-Sport Leaders program positions beginning in September (student positions).

Church Street Roundabout traffic flow improvements.

Antigonish Culture Alive planning a new mural.

Line painting and street maintenance updates, including crosswalk safety at Acadia Street and Main/Library; staff to provide further recommendations.

Suggestions for improved lighting and pedestrian beacons.

Council acknowledged the staff updates and ongoing efforts.

Acceptance of Reports:

Moved: Councillor Murray

Seconded: Councillor MacLellan

Motion: To accept the staff reports as presented.

Motion Carried

Council recessed at 8:10 p.m. and moved to In-Camera.

DRAFT

10. In-Camera

10.1 Contract Negotiations – MGA Sec. 22(2)(e)

Council moved to In-Camera to discuss contract negotiations under Section 22(2)(e) of the Municipal Government Act. (MGA)

Council moved out of In-Camera at 9:25 p.m.

Moved: Councillor MacLellan

Seconded: Councillor Murray

11. Adjournment

With no further business the meeting was adjourned at 9:24 PM

Mayor Sean Cameron

Randy Delorey, CAO

DRAFT

**Special Council Meeting
September 2, 2025
Town Council Chambers**

Present

Mayor S. Cameron
Deputy Mayor D. Roberts
Councillor L. MacLellan
Councillor, P. McKenna
Councillor A. Murray
Councillor J. Pelly
Councillor J. Sullivan

Also in Attendance

R. Delorey, CAO
M. Fougere, Deputy Clerk
M. Williams, Marketing and Communications Officer
M. Barkhouse, Director of Corporate Services

1. Call to Order

Mayor Cameron called the meeting to order at 8:55 PM.

2. Approval of Agenda

Moved: Councillor
Seconded: Councillor

Motion: To approve the Agenda as presented.

3. Business from Committee of the Whole

3.1 Human Resource Policy Update – Preventing Workplace Harassment Policy

A memo was circulated at the Committee of the Whole meeting held on September 2, 2025, outlining recent changes to the Nova Scotia Workplace Harassment Regulations under the Stronger Workplaces for Nova Scotia Act, effective September 1, 2025. Corporate Services recommended updates to the Town's Workplace Harassment Policy (HR Manual, Section 16-1) to ensure compliance with the new regulations.

Moved: Councillor MacLellan
Seconded: Councillor Murray

Motion: That Council adopt the Human Resource Policy Update – Preventing Workplace Harassment Policy as presented.

Motion Carried

4. Adjournment

With no further business the meeting was adjourned at 8:57 PM.

Mayor Sean Cameron

Randy Delorey, CAO

To: Town Council
Chief Administrative Officer

Submitted by: Melanie Fougere, Deputy Clerk, on behalf of the Beautification Committee

Date: Thursday, July 31, 2025

Subject: Beautification Recognition

At the Beautification Committee meeting held in May 2025, the following motion was passed:

"That Oona Laundry be formally recognized for her outstanding volunteer contributions with a certificate of appreciation in gratitude for her lasting impact on the Town of Antigonish."

Councillor Murray has requested that this item be brought forward for Council's consideration, in keeping with the process outlined in the Town's Municipal Acknowledgment Policy.

Should Council support the recognition, staff will coordinate with Councillor Murray to invite Ms. Laundry to an upcoming Council meeting where a certificate of appreciation can be formally presented.



Flag/Banner Request

Applicant Information

1. Community Group/Organization Title:

285 RCACC/875 RCACS

2. Applicant Name:

Second Lieutenant Stacey Nixon

3. Email:

stacey.nixon@cadets.gc.ca

4. Address:

26 MacMillan Road

5. Postal Code:

B2G 2L4

6. Phone:

902-870-7579

Request Details

7. Please indicate your request:

- Flag
- Lamp Post Banner
- Other

8. If requesting a flag raising, please indicate what the flag is.

Cadets Canada Flag

9. What type of event does your request coincide with?

- Parade
- Community Event
- Designated Month
- Memorial Recognition
- Festival/Celebration
- Other

10. Please indicate the date(s) your organization would like to have you flag/banner request fulfilled.

Flag/Banner Request Start Date:

04 Oct, 2025

11. Flag/Banner Request End Date:

06 Oct, 2025

12. Does your event require an official flag raising ceremony with Mayor and Council?

Yes

No

13. Additional information: (Please provide an overview of your request and how the addition of a flag to Chisholm Park or lamp post banners will benefit your event, celebration, or memorial).

Please see email.

Permissions

Special Considerations

- Flags will be flown at Chisholm Park.
- Banners must be designed to be 18 inches by 44 inches and be made from vinyl material. Banners must be designed and installed to the standard set by the Town.
- The Town reserves the right to inspect any flag or banner prior to placement on Town owned property. Flags or banners will not be placed by the Town if:
 - i) The material is tattered, frayed, damaged or detracts from the beautification of the Town.
 - ii) The flag or banner promotes discrimination or philosophy or seek values are deemed to be divisive or discriminatory.
 - iii) The flag or banner contradicts the guidelines in place in the Town's Special Events Planning Guide.
 - iv) No flag or banner can be suspended across the street.

Declaration

I, the undersigned, have read, understand, and agree to the conditions and policies in this contract hereby accept the same on behalf of the said members of the organization or group. I acknowledge and agree that the Town will make the final decision on this flag/banner request.

14. Signature:



15. Date:

25 Aug, 2025

Melanie Fougere

From: Melanie.Fougere@townofantigonish.ca
Subject: FW: EXTERNAL: Flag raising request form
Attachments: Cadet Day Flag Request Form.pdf

From: Nixon 2Lt SAS [REDACTED]
Sent: Monday, August 25, 2025 9:21 PM
To: Mikaela Williams <mikaela.williams@townofantigonish.ca>
Subject: EXTERNAL: Flag raising request form

CAUTION: This email originated from outside of the organization. Do not click links or open attachments unless you recognize the sender and know the content is safe.

Good evening,

Please see attached form.

We are requesting to raise the Cadets Canada flag in Chisholm Park, 04 Oct-06 Oct.

We would like to have a small ceremony, which would be open to the public, where 2 cadets will each make a short speech, our Commanding Officer will speak, and we request that the Mayor, or a representative from the Town of Antigonish also say a few short words similar to how we did last October.

Should you need any additional information, please let me know.

Respectfully,

2Lt | Slt Stacey Nixon

Training Officer, 285 Antigonish Royal Canadian Army Cadet Corps, Regional Cadet Support Unit (Atlantic) / Cadets and Junior Canadian Rangers
Vice Chief of the Defense Staff / Canadian Armed Forces

[REDACTED]

Capital Update Fiscal Year 25/26

Department of Infrastructure and Engineering
(DIE)

Sept 15th, 2025



Major Projects

Based on Council's Strategic Priorities and the Town's current needs, the budget was put together to address the following major projects:

- Bay St
- West St / James St
- Sewage Treatment Plant Front End
- PW Equipment
- Source Water Test Wells
- Sidewalks

Tenders to date (14):

- PW Equipment
 - New Loader – closed and awarded
 - Sale of Old Loader – closed and awarded
 - Single Axle Salt Truck – closed and awarded
- Service Vehicles – closed and awarded
- Greening Drive Design – closed and awarded
- Electric Grid Modernization:
 - Substation Transformer Assembly – closed and awarded
 - Substation Civil Works – closed and awarded
 - Substation Steel Structures – closed and awarded
- Sewage Flow Study – closed and awarded
- Safety Management System – closed Aug 14th, under review
- Patching Tender – closed Aug 28th, under review
- STP Screening Equipment – closed Sept 8th, under review
- STP Aeration Equipment – closes Sept 19th
- Test Well Drilling – Closes Sept 29th

Pending Tenders – West St / James St

- Tender is ready for release for Sewer Main Lining for James / West.
- **Tender has been held due to concerns raised at Committee of the Whole.**
- **We recommend that we proceed with the release of the tenders, acknowledging the concerns over lateness in the year.**
- West/James Phase 1 Plan (2025):
 - Tender Lining of Sewer Main to fix issues with broken pipe.
 - Tender asphalt resurfacing, curb and sidewalk from West/James to West/Highland. Pave the area of West St that has been an issue due to AT changes.
 - Complete in 2025.
- West/James Phase 2 Plan (the rest):
 - Tender Water Main (West/James to roundabout) in spring along with remaining street asphalt, curb, sidewalk.
- If we do not proceed, we risk losing ~\$500k in one-time Trunks & Routes funding from the province that cannot be carried over.



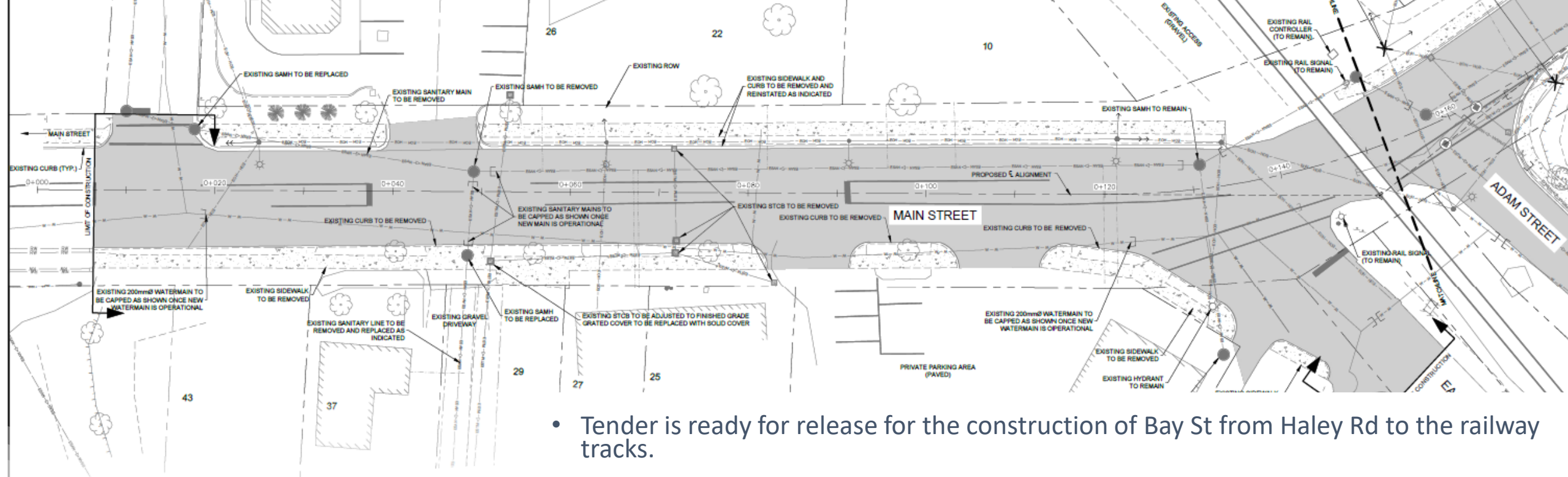

- Tender is ready for release for the construction of Bay St from Haley Rd to the railway tracks.
- **Tender has been held due to concerns raised at Committee of the Whole.**
- **We recommend that we proceed with the release of the tenders, acknowledging the concerns over lateness in the year.**
- Bay St Phase 1 Plan (due to holdups from Railway / Utilities):
 - Tender Construction from Haley Rd to Railway tracks (not dependant on approvals or 3rd parties), including pipes, asphalt, curbs, sidewalk, AT + jack and bore under rail line.
 - Complete railway agreements and negotiations.
 - Move communication utilities infrastructure to new pole line, clear trees.
 - Complete in 2025.
- Bay St Phase 2 Plan (the rest):
 - Tender remaining section (Railway to Town Boundary) in spring 2026.
 - Includes pipes, curb, asphalt, sidewalk, crosswalk.

Pending Tenders – Bay Street

Asphalt Patching Tender

- Tender closed Aug 28th, under review + not yet awarded.
- Prices for this work continue to increase 20 – 30% per year. We will be undertaking this work differently next year.
- Tender is double the available budget (~\$400k vs \$200k)
 - Note: Quantities were increased over last year to attempt to get better pricing + address known issue areas.
- Options for this year:
 - 1) Scale back to budget (cut areas to be milled and filled by half) - recommended
 - Cut Hawthorne St?
 - Cut everything else?
 - 2) Cancel 2025 work, plan larger patching project for 2026.

Sidewalk Capital – Greening Dr

- Work is now underway for the Greening Drive Sidewalk Project.
 - PW (regular crew) is installing new catch basins and working on underground pipe work.
 - Concrete crew will be following along next week.
 - Design was completed by Strum, and notices were given to the affected properties.
 - Sidewalk will be on the western side of the roadway (even house numbers).
 - No issues flagged at this time.



Strategic 3-Year Capital Plan

- Costs updated to reflect current funding applications.
- Baseline for development of 2025/2026 Capital Budget
- Updated for creation of 5-year CIP

	Average cost per year
General Capital	\$ 4,759,806.62
Water	\$ 5,064,657.68
Sewer	\$ 1,301,284.00
Electric	\$ 2,589,333.33

3 Year Capital Plan	If All Funding Received			
	YR1	YR2	YR3	
Sewer Plant - Front End	\$ 1,350,000.00	\$ 450,000.00		
Sewer Plant - Capacity Upgrade				
Source Water	\$ 187,000.00		\$ 3,339,089.00	
BBWTP Backwash Ponds		\$ 650,000.00		
Northern Collector				
PW Equipment	\$ 780,000.00	\$ 390,000.00	\$ 390,000.00	
Brierly Tank		\$ 5,200,000.00		
College St Bridge				
PW Building	\$ 50,000.00	\$ 300,000.00	\$ 50,000.00	
Town Hall		\$ 390,000.00	\$ 1,067,300.00	
Grid Modernization (EU)	\$ 5,788,000.00	\$ 1,603,000.00	\$ 377,000.00	
West St	\$ 1,075,000.00			
James St	\$ 275,000.00			
Farmers Market Parking Lot				
Bay St (including CD Proj D)	\$ 1,516,055.89			
Hawthorne (Pleasant to Brookland)		\$ 2,056,500.00		
Hawthorne (Xavier to Pine)			\$ 3,444,350.00	
Hawthorne (Pine to MacDougall)			\$ 5,244,950.00	
Main St (Hawthorne to Elm)				
College St (St Ninian to Pleasant)		\$ 3,293,000.00		
St Ninian St (Highland to Church)				
Highland Dr				
College St to Cloverville				
Water Transmission Line - Brierly				
AT Project B and C		\$ 995,000.00		
Trunk Sewers		\$ 520,000.00	\$ 364,000.00	
Church St				
Viewville St				
Xavier Dr				
Water Transmission Line - The Rest				
Yearly Total	\$11,021,055.89	\$15,847,500.00	\$14,276,689.00	\$ 41,145,244.89
Water Utility	\$ 626,784.03	\$ 7,194,200.00	\$ 7,372,989.00	\$ 15,193,973.03
Electric Utility	\$ 5,788,000.00	\$ 1,603,000.00	\$ 377,000.00	\$ 7,768,000.00
Sewer Utility	\$ 1,633,852.01	\$ 1,282,000.00	\$ 988,000.00	\$ 3,903,852.01
General Capital (Tax Rate Impact)	\$ 2,972,419.85	\$ 5,768,300.00	\$ 5,538,700.00	\$ 14,279,419.85
				\$ 41,145,244.89

2025/2026

2026/2027

2027/2028

3 Year Plan

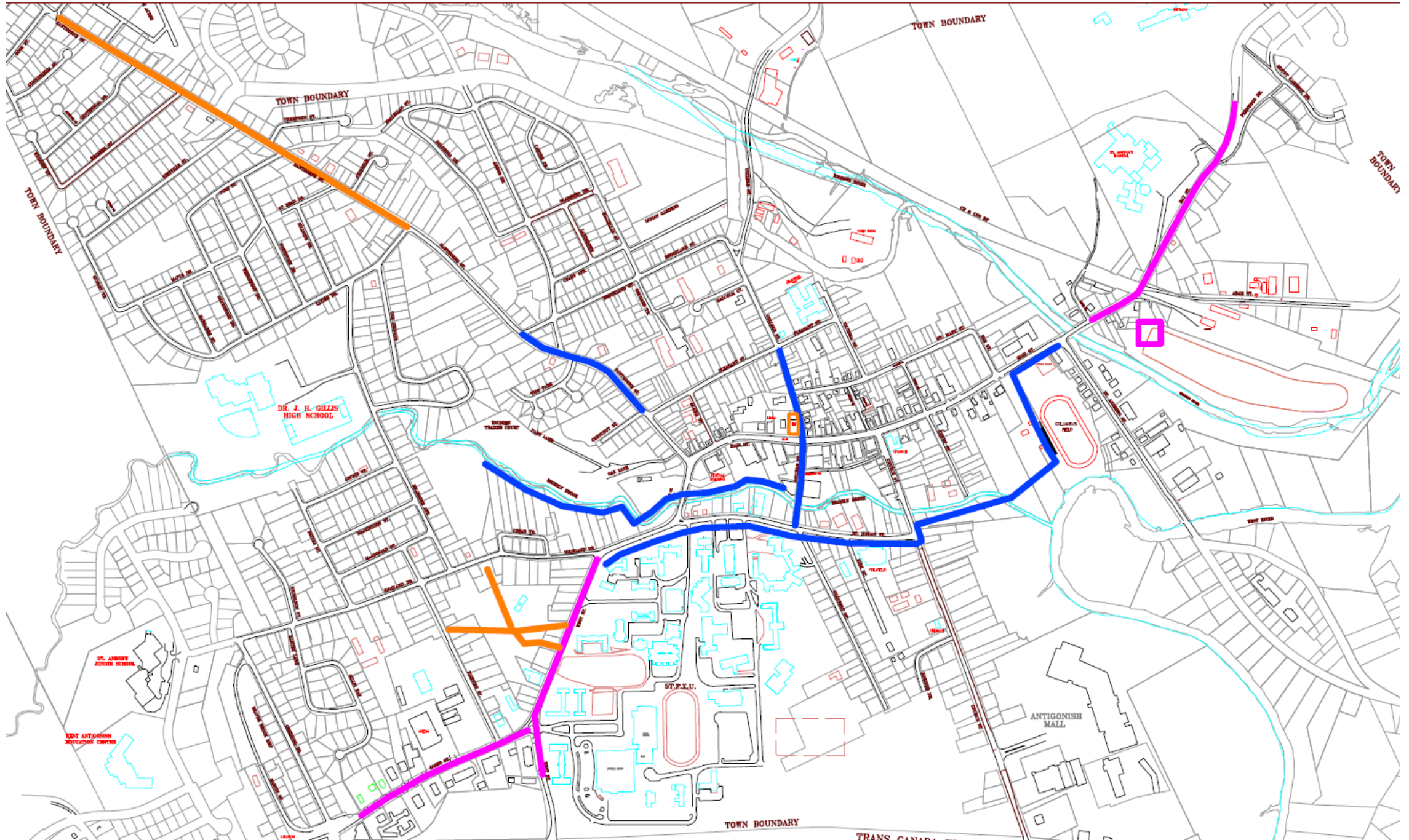

Capital Investment Plan (CIP) Updating

5 Year Capital Plan	If All Funding Received				
	25/26	26/27	27/28	28/29	29/30
	YR1	YR2	YR3	YR4	YR5
Sewer Plant - Front End	\$ 1,350,000.00	\$ 450,000.00			
Sewer Plant - Capacity Upgrade				\$ 6,803,000.00	
Source Water Wells	\$ 187,000.00		\$ 3,486,000.00		
BBWTP Backwash Ponds		\$ 650,000.00			
Northern Collector		\$ 875,000.00			\$ 4,345,000.00
PW Equipment	\$ 780,000.00	\$ 390,000.00	\$ 390,000.00	\$ 390,000.00	\$ 390,000.00
Brierly Tank		\$ 4,000,000.00			
College St Bridge				\$ 2,600,000.00	
PW Building	\$ 50,000.00	\$ 300,000.00	\$ 50,000.00	\$ 50,000.00	\$ 50,000.00
Town Hall		\$ 390,000.00	\$ 1,067,300.00		
Grid Modernization (EU)	\$ 5,788,000.00	\$ 1,603,000.00	\$ 377,000.00	\$ 86,000.00	
West St	\$ 825,703.20				
James St	\$ 272,300.70				
Creighton Lane Parking Lot			\$ 865,000.00		
Bay St (including CD Proj D)	\$ 2,143,000.00				
Hawthorne (Pleasant to Brookland)		\$ 2,056,500.00			
Hawthorne (Xavier to Pine)			\$ 3,444,350.00		
Hawthorne (Pine to MacDougall)				\$ 5,244,950.00	
Main St (Hawthorne to Church)					\$ 5,257,775.00
AT Project B and C		\$ 995,000.00			
Trunk Sewers		\$ 520,000.00	\$ 364,000.00		
Yearly Total	\$11,396,003.90	\$12,229,500.00	\$10,043,650.00	\$15,173,950.00	\$10,042,775.00

Summary

- Work is underway on all fronts, and the Dept is extremely busy delivering the proposed work.
- Tenders can start going out tomorrow for Bay St and West St unless motioned otherwise.
- Capital planning is underway in the background, with updates to CIP and longer-term capital plans. More of this will follow in late fall / early winter.
- Will proceed as recommended on awarding Patching Tender unless discussions indicate otherwise.

Questions?



Sewer / Water Update

Department of Infrastructure and Engineering

Sept 15th, 2025



Sewage Treatment Plant



Odor Issue - 2025

- Odor started this year around July 1st, 2025, approximately the same time as the heat waves started. Specifically, once lagoon temperature went above 20C, the odor issue followed shortly thereafter.
- The odor event was no longer normally detectable outside the Plant fence line by ~Aug 14th 2025. (6 weeks)
- The odor was no longer detectable inside the fence line by ~Sept 1st 2025. (8 weeks)
- While noticeable and detectable across town at times, the odor was not as pronounced as last year.

Lagoon Temperature vs Dissolved Oxygen

Series1 Series2 Cell 1B Line 7 Cell 1B Line 9 High Temp 20 Degrees 0.5 line Linear (Series2)

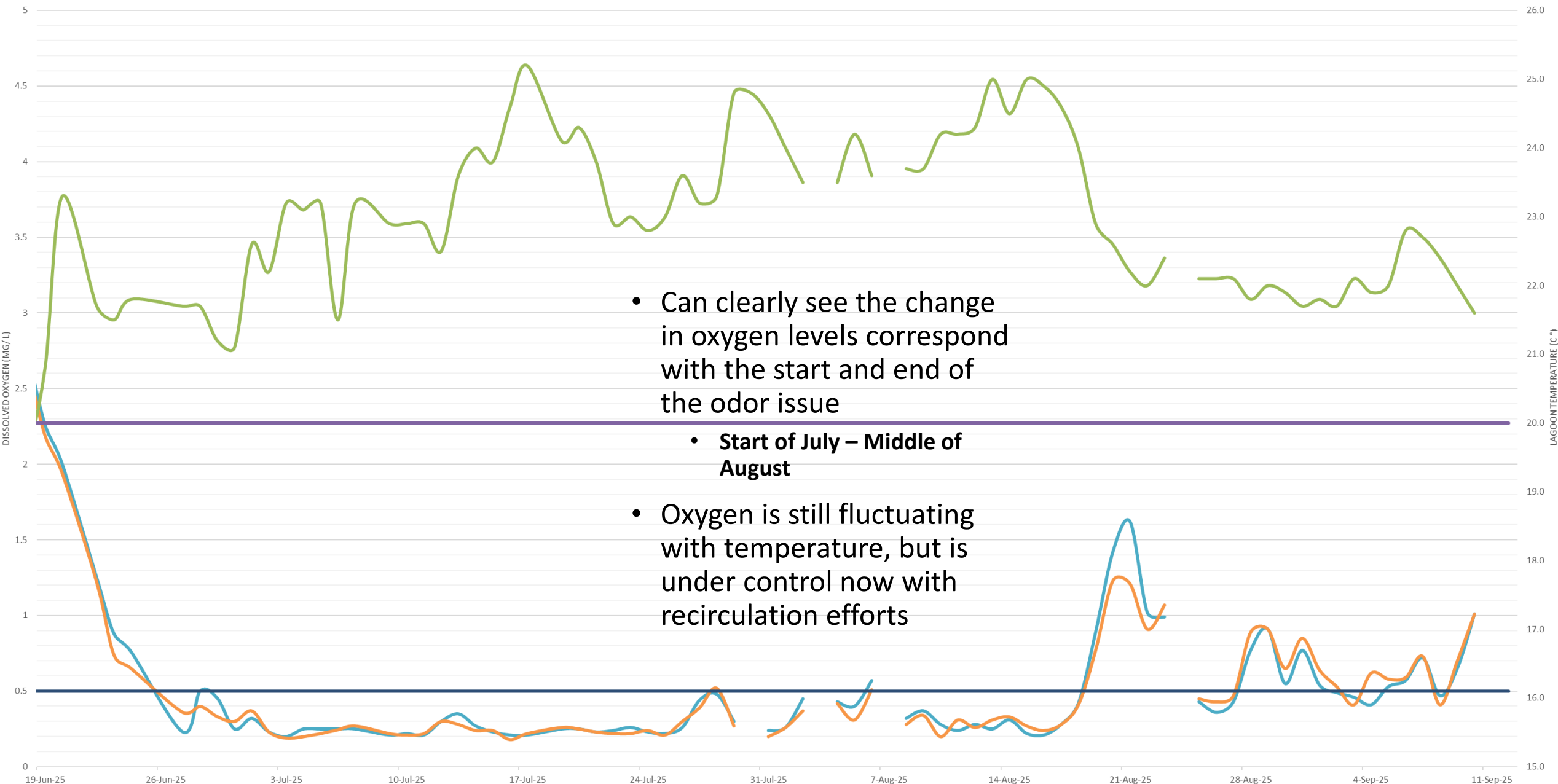

- Can clearly see the change in oxygen levels correspond with the start and end of the odor issue

- **Start of July – Middle of August**

- Oxygen is still fluctuating with temperature, but is under control now with recirculation efforts

Recirculation of Flow (Pumping)

- CBCL's main recommendation was to recirculate plant flow from the back of the plant (high O₂) to the front of the plant (low O₂)
- A 6" diesel pump was rented and installed July 29th 2025 with approximately 800 feet of hose (capacity ~1M gallons per day).
- Oxygen rich water was pumped from Cell 2B to Cell 1A in the lagoon, with monitoring by operations staff.
- 2 – 3 weeks later, oxygen levels began to recover, and the issue was resolved.



Increased Aeration

- While recirculation has resolved the issue, we are still working on the other avenues to fight odor, primarily through increased aeration.
- 5 additional aeration units were installed into the front of the plant to increase the amount of air going into the wastewater.
- An Aeration Equipment Tender was released Aug 29th, 2025 for the purchase of enough aeration equipment to effectively double the amount of air in the first cell of the lagoon. Tender closes Sept 19th, interest from multiple parties.
- Blower refurbishment underway, temporary skid being constructed for installation in front of plant.

Additional Mitigation Measures

- **Addition of cold water to lagoon:**

- In an effort to help decrease temperatures and boost oxygen, a system was set up to add cold water to the lagoon safely through the recirculation system, via a fire hydrant.
- This was run for 2 short durations, (each ~3 days to a week) then discontinued with Water Conservation Measures. All water was metered and backflow protected for safety.
- This did appear to have an impact decreasing odor, and will be a useful tool for next year / later this fall once dam levels are recharged.

- **Addition of de-odorizer:**

- Addition of 2 different types of de-odorizers has been fully automated for the month of September.

- **Rags and Floatables:**

- Significant work has been done this year to remove rags and debris from the aeration system manually (as we have no screening system currently).
- Floatables have increased noticeably in the month of September, operators have increased removal efforts and spot spraying for odor.



STP Screening Project

- Screening Equipment Tender:
 - Closed Sept 8th, with 3 bids received for the supply and installation of mechanical equipment.
 - Bids are currently under review by CBCL for best performance vs cost, and we should be ready to award by Sept 19th.
- Site Civil Works Tender:
 - Final preparation underway for geotechnical next week (line tracing, etc).
 - Tender should be released shortly after results received.

Screening / Blower Building Concept

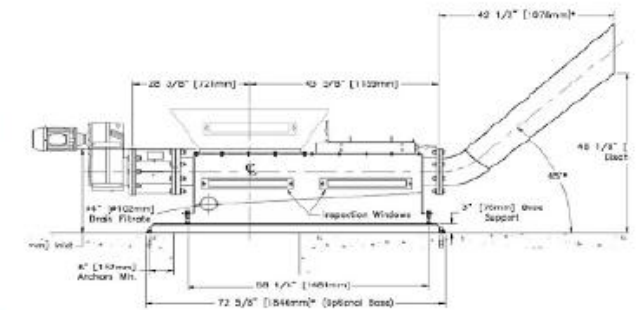
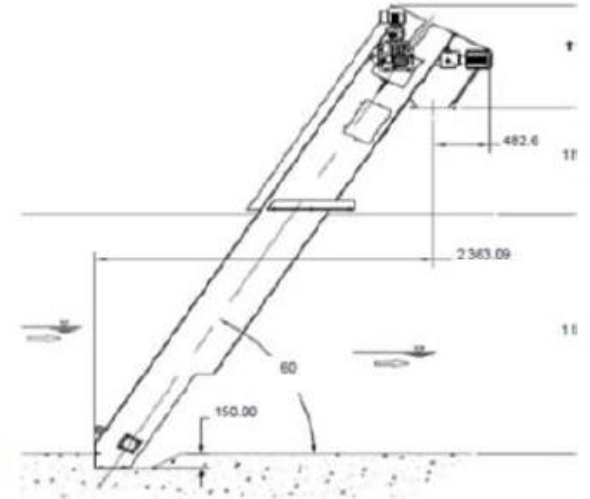

Sewage Flow Study – Update for Sept 2025

- Contract awarded to RVA in partnership with BioMaxx Environmental
- Scope:
 - Sewage flow monitoring across Town / County common sanitary system
 - Inflow and Infiltration (I&I) assessment
 - Expanded to include manhole survey
- Schedule:
 - Flow monitor installation planned for week of Sept 22nd to start 1-year data collection period.
- Next Steps:
 - Installation, data collection
 - Ongoing analysis and reporting to support system planning and Intermunicipal Agreement update.

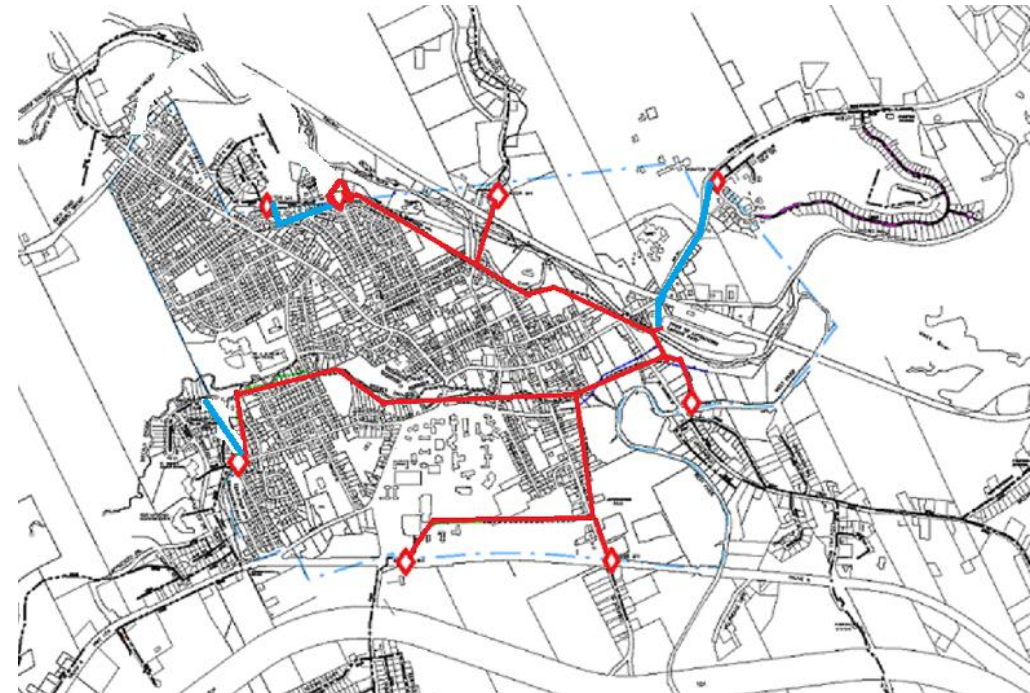

Red = Common lines under Agreement
Blue = Common lines added after Agreement

Discussion



Source Water / Conservation Measures



Source Water

- James River Dam
 - Last upgraded in 1998 for additional storage
 - Conservation Measures have been enacted 5 times in the last 9 years due to dam levels (3 voluntary, 2 mandatory).
 - Current studies show insufficient storage for 1:20 year drought
- Search for Additional Source Water
 - Studies have been undertaken to assess for other feasible sources of water
 - Test Wells are planned in the Brierly Brook to James River area this October (2025).
 - The untapped aquifer there may yield up to $\sim 2,000\text{m}^3/\text{day}$ ($\sim 50\%$ of current usage)
 - The Housing Accelerator Fund (HAF) includes funding to support source water exploration jointly for the Town and County.
 - Discussions with ~ 4 property owners are underway for drilling permissions.



2025 Water Conservation Measures

- The dam first stopped spilling in the early hours of July 14th.
- As per our Water Supply Contingency Plan, we enacted Voluntary Conservation Measures July 17th due to a lack of rain in the immediate forecast.
- We enacted Mandatory Conservation Measures August 6th, corresponding with hitting the 1m down mark (as required by Permit).
- We received 25mm of rainfall at the dam the night of Aug 25th, which led to a slow rise in dam levels of about 5ft over multiple days, from 7.5ft down, to ~2.5 ft down.
- Mandatory Conservation Measures were lifted August 29th as levels rose above the 1m down mark.
- We currently remain in Voluntary Conservation Measures.
- Water levels have remained largely constant at the dam, even with the return of STFX students and the lifting of Mandatory Conservation Measures.



Dam Levels

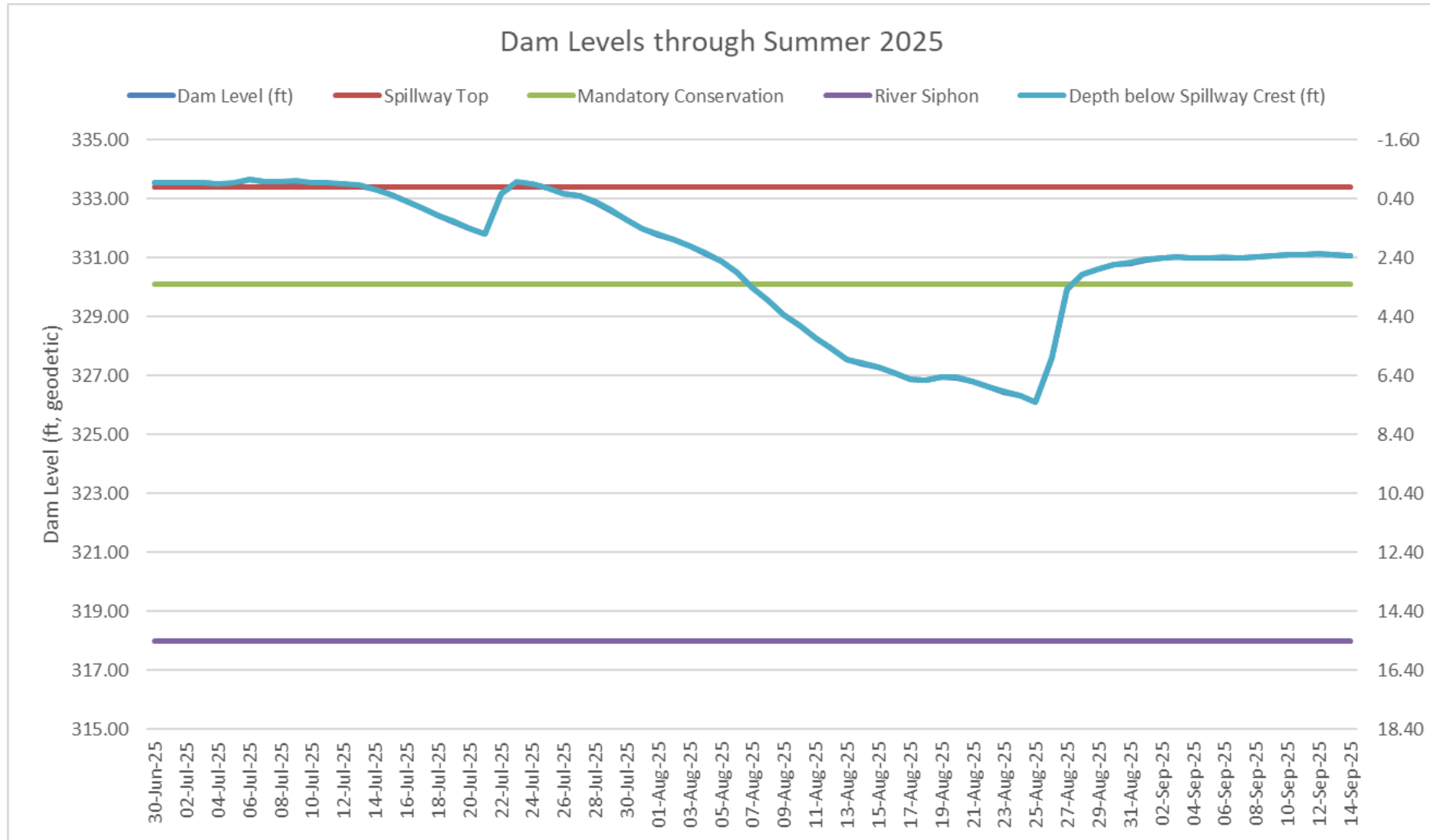

Water Contingency Measures Part 1

- Mandatory Conservation Measures do appear to have had an impact on water usage, dropping our overall consumption from ~4,500m³/day to ~4,000m³/day, or around 11%.
- As part of our standard contingency plan, the Wrights River (County) Wells were activated upon starting Mandatory Conservation, supplying ~760m³ per day.
- Public Works staff also made a concentrated effort on leak detection, and were able to identify and fix multiple leaks in the system.
- Treatment Facilities were able to scale back the amount of water used in internal processes in the plants, to minimize water wastage.

Water Contingency Measures Part 2

To ensure maximum preservation of our water supply, several extra measures were undertaken:

- In consultation with NSE and DFO, an amendment was submitted for the Water Withdrawal Permit to decrease fish flow in emergency conditions. Currently under review.
- In accordance with the submitted amendment, siphon flow was valved back to minimum levels for the James River system (1.7cfs to 1.1cfs) as per hydrogeologist recommendations.



Water Contingency Measures Part 3

- Several Antigonish Regional EMO meetings were held to discuss and plan further contingency action in August, including;
 - Plans were started to assess feasibility of using additional water supplies to supplement the supply to the Brierly Brook Water Treatment Plant.
 - A fitting was made to allow connection of water tankers to the raw water transmission line via a pumping system.
 - Contact was made with STFX to assess their irrigation wells for use in trucking to supplement supply to the plant.
 - Mandatory Measures were lifted prior to the tests being undertaken, and work was paused. We intend to complete the tests and truck a shipment of water as a trial to add to the treatment plant.

Questions?



Pictou-Antigonish Regional Library Activity

Library Visits by Location		
	2023/2024	2024/2025
Antigonish	144,754	161,362
Books-By-Mail	N/A	
New Glasgow	66,428	62,828
Pictou	26,851	49,356
River John	7,747	9,510
Stellarton	18,024	19,126
Trenton	9,747	11,274
Westville	21,411	23,889

Population Served	64,369
Total Holdings	139,760
Summer Reading Program Participants	449 ballots 3635 complete activities
Number of staff	60

24/25 Income		24/25 Expenditure	
Provincial Grant	\$ 451,100	Salaries/Benefits	\$ 1,848,016
Municipal Grant	\$ 581,663	Books & Materials	\$ 205,866
Board Income	\$ 783,555	Administration	\$ 565,792
TOTAL	\$ 2,816,318	TOTAL	\$ 2,619,674
Accumulated Deficit			\$ 186,523

Major Sponsors

Adopt-A-Library Literacy Program
 Friends of the Antigonish Library
 Friends of the River John Library
 Our Communities

Library Board

Province of Nova Scotia:

Rev. Greg Dickson
 (from Sept. 2024-)

Kathy Campbell
 (Sept. 2024 – Feb. 2025)

Municipality of the County of Antigonish:
 Coun. Mary MacLellan

Municipality of Pictou County:
 Coun. Deborah Wadden

Town of Antigonish:
 Coun. Sean Cameron
 (to Oct. '24)

Coun. Patrick McKenna
 (from Nov. 2024)

Town of New Glasgow:
 Coun. Clyde Fraser
 (Chair from November 2024)

Town of Pictou:
 Coun. Dan Currie
 (Chair to October 2024)

Coun. Robert Fry
 (from Nov. 2024)

Town of Stellarton:
 Coun. Simon Lownd
 (to Oct. '24)

Deputy Mayor Sandra Eis
 (from Nov. '2024)

Town of Trenton:
 Coun. Nicole LeBlanc

Town of Westville:
 Coun. Sarah Mackinnon,
 (to October 2024)

Coun Helen Dunn
 (from Nov. 2024)

Library Management Staff

ERIC STACKHOUSE
 Chief Librarian/ Board Secretary

TRECIA SCHELL
 Community Services Librarian

MANSI NISHIT TRIVEDI
 Technical Services Librarian

KAREN MACNEILL
 Office Manager

JEAN ROZEE
 Finance Manager

JES DAVEY
 Manager of Web Services

MELANIE PAULS
 Community Access to
 Technology Coordinator

KRISTEL FLEUREN-HUNTER
 Children's Services Librarian

REGIONAL LIBRARY

Annual Report



April 2024 – March 2025

www.parl.ns.ca

Chairperson's Report 2024/2025

After 10 years of planning, the Murray Family Public Library opened in Pictou on September 23, 2024 in the new and renovated deCoste Culture Hub. Congratulations to the Town of Pictou, the Municipality of the County of Pictou, the deCoste Entertainment Society and the community for their support of an amazing complex. Not only does the complex feature a new library and renovated theatre but includes workshop and office space for Creative Pictou County, community meeting spaces, world-class public art, a new boardwalk and sea stairs, and a gallery to showcase local arts and culture.

Most important, the community loves their new space with over 32,000 visits in the first six months. The official opening of the deCoste Culture Hub was held November 1, 2025. Thank you to our community, municipal, provincial and federal funding partners.

The success of the project above can be contrasted with the disappointment felt by the regional library board in February when Library Funding Formula Committee recommendations were not accepted by the provincial government. With no increase in provincial base funding the board will struggle to maintain hours, services, and programs at current levels. It is clear communities and government want more of what public libraries offer. At the same time, the Funding Formula Committee indicated public libraries were at risk if not properly resourced. The Board, with municipal partners, will continue to urge the provincial government to work towards a resolution in the near future.

The board welcomed two new provincial appointees in June, Greg Dickson and Kathy Campbell. Unfortunately, Kathy was unable to continue due to family commitments. The board has notified officials with Communities, Culture, Tourism, and Heritage and requested a replacement.

The municipal elections of October 2024 resulted in several changes to board membership. The board wishes to express its sincere thanks to councillors Dan Currie, Simon Lawand, Sean Cameron and Sarah Mackinnon for their dedication and support while members. The board would like to welcome new board members, councillors Robert Fry, Sandra Eis, Helen Dunn, and Patrick McKenna.

The renewal of the New Glasgow Library and Regional Headquarters is now underway. The Town of New Glasgow selected general contractor PCL to take on this \$12 million project. It will take two years to complete and both the library and headquarters will move elsewhere during this time.

Finally, I wish to thank board members past and present for their ongoing support. Also, to all of our employees, sincere thanks for all of your work and the caring you show while supporting our communities.

Clyde Fraser, Chair
Pictou-Antigonish Regional Library

Chief Librarian's Report 2024/2025

This was a busy year for the regional library. The new Murray Family Library, located in Pictou, opened in September to rave reviews. The New Glasgow Library and HQ renovation project moved forward with an expected construction start of spring 2025. Many improvements have been made in branches across the region, especially in accessibility. Thank you to all levels of government for their support. A special thank you to our communities, it is clear they want welcoming and vibrant libraries offering a range of experiences.

And the statistics show this. Every year since the launch of Same Page our circulation has grown, this year saw a 2% increase, even though a postal strike interrupted the movement of books across the province. Library visits increased by 14%, with 337,345 visits to a library in PARL during the year. Of special interest is the 28% increase in information questions answered, which can be directly linked to more people looking for help finding and using government information. Public libraries have truly become community hubs.

In the spring of 2024 I was asked to Co-Chair the Regional Library Funding Review Committee. It was a positive experience, working with leaders from government, municipalities, and library boards, to identify the financial needs of public libraries over the next five years. What was obvious is how libraries have changed in the past 20 years and how much they support government services and community priorities. It was also very clear libraries faced an uncertain future in staffing, collections, and technology without provincial government leadership and investment. Recommendations were made to the Minister of Communities, Culture, Tourism, and Heritage in September. It was with deep disappointment that we learned government chose not to act on those recommendations in its February budget. While their reasoning is understood, global financial uncertainty, it fails to recognize that during times of uncertainty, citizens need and ask more from public libraries.

I cannot review in this short space all the good work of the board's employees. From innovative projects, amazing partnerships, exciting programs, and service with caring and compassion, library workers have shown tremendous resilience. I urge the provincial leadership to recognize how essential this work is and fund it correctly.

Eric Stackhouse, Chief Librarian and Board Secretary
Pictou-Antigonish Regional Library

Pictou-Antigonish Regional Library Activity

Library Use	2023/24	2024/25
Materials Borrowed	368,884	375,097
Digital Materials Borrowed	95,797	92,823
Active Users	13,617	14,659
Library Visits per year	294,962	337,345
Information Questions	22,791	27,193
Virtual Library Visits	365,777	273,840
Electronic Database Sessions	25,378	20,724
Internet Bookings	32,158	32,230
Internet Training Programs	812	1,040
Library Programs	1,389	1,570
Library Program Attendance	13,434	14,151
Items Borrowed from Other Libraries	461	484
Items Lent to Other Libraries	507	462
Nova Story Page Views (Ant. & Pic.)	147,422	149,382

Materials Borrowed by Location (Renewals excluded)	2023/24	2024/25
Antigonish	103,095	99,385
Books-By-Mail	6,747	6,617
New Glasgow	69,339	60,650
Pictou	35,752	41,943
River John	7,605	8,158
Stellarton	26,776	27,908
Trenton	4,680	5,147
Westville	13,525	14,031

Melanie Fougere

From: Melanie.Fougere@townofantigonish.ca
Subject: FW: concert with Alan Syliboy and the Thundermakers on National Day of Truth and Reconciliation

From: Town of Antigonish Mayor <mayor@townofantigonish.ca>
Sent: Wednesday, September 3, 2025 2:27:41 PM
To: Leon MacLellan <leon.maclellan@townofantigonish.ca>; Jack Sullivan <jack.sullivan@townofantigonish.ca>; Patrick McKenna <patrick.mckenna@townofantigonish.ca>; Juanita Pelly <juanita.pelly@townofantigonish.ca>; Diane Roberts <Diane.Roberts@townofantigonish.ca>; Andrew Murray <Andrew.Murray@townofantigonish.ca>
Cc: Randy Delorey <Randy.Delorey@townofantigonish.ca>; Melanie Fougere <Melanie.Fougere@townofantigonish.ca>
Subject: concert with Alan Syliboy and the Thundermakers on National Day of Truth and Reconciliation

Members of Council

Forwarding this request of funding \$4000 for a concert commemorating the National day of truth and reconciliation.

Melanie, please add this to the agenda for Sept. 15 Council meeting.

Sincerely

Sean Cameron
Mayor, Town of Antigonish
902-318-6745

From: Marlis Lade [REDACTED]
Sent: Monday, August 25, 2025 10:16:44 AM
To: Town of Antigonish Mayor <mayor@townofantigonish.ca>
Subject: EXTERNAL: concert with Alan Syliboy and the Thundermakers on National Day of Truth and Reconciliation

CAUTION: This email originated from outside of the organization. Do not click links or open attachments unless you recognize the sender and know the content is safe.

Dear Mayor Cameron,

This year, we are excited to host Alan Syliboy and the Thundermakers for their third annual concert, which will be held in commemoration of the National Day of Truth and Reconciliation.

Reconciliation is an important topic at our university, and we believe this concert will provide a unique and educational experience that extends beyond StFX. We would like the town of Antigonish to participate in the celebrations for the National Day of Truth and Reconciliation.

As September 30th approaches, I want to highlight that costs and organizations are involved in this project. The fee for the band to perform and share their story is \$4,000 in addition to the cost of booking a sound system.

I kindly request your support in making this concert happen by generously providing funding for this important event, as you did in previous years. A response by September 3 would be greatly appreciated.

Sincerely
Marlis

Marlis Lade
German coordinator at StFX, MEd
Nicholson Tower 413



MARLIS LADE

I acknowledge that St. Francis Xavier University is located in Mi'kma'ki, the ancestral and unceded territory of the Mi'kmaq people.

September 8, 2025

Dear Randy,

I'm excited to share that [GenWell](#), the Human Connection Movement, is coming to Antigonish on Wednesday, October 29th and Thursday, October 30th.

[GenWell](#) is a national not-for-profit focused on the power of human-to-human connection and its impact on our mental, emotional, and community well-being. In a time where disconnection is becoming more common, GenWell is here to inspire and empower us to reconnect - with ourselves, each other, and our communities.

Throughout GenWell's time in Antigonish, there will be interactive workshops on StFX campus, and an evening keynote delivered by GenWell CEO, Pete Bombaci at Barrick Auditorium. Pete's dynamic presentation will shed light on the critical role of social connections in enhancing both personal well-being and professional success, and how we can each play a part in creating a more connected, healthier community and campus culture.

To make this event as impactful and accessible as possible, we are currently seeking sponsorship support. I am hopeful that the Town of Antigonish will see the value in promoting social connection as an integral part of a healthy community. There is an opportunity for Genwell to do a presentation to Town and County staff on Thursday morning if you'd like to get involved!

To be human is to need connection.

With appreciation in advance,
Emilie Chiasson





GenWell Human Connection 101 Workshop Agenda

- 1. The History of Human Connection**
 - An exploration of how human connection has shaped societies, cultures, and personal well-being throughout history.
- 2. The Consequences of Connection and Disconnection**
 - **Negative Consequences:** The impacts of social isolation, loneliness, and disconnection on individuals and society, including physical, mental, and economic effects.
 - **Positive Consequences:** The transformative power of connection in fostering happiness, health, and overall well-being of individuals and communities.
- 3. Understanding Loneliness**
 - Definitions and distinctions: social isolation, disconnection, and loneliness.
 - Insights into the universal experience of loneliness and how it is experienced across different demographics.
- 4. Causes of Loneliness**
 - A deep dive into factors contributing to loneliness, including societal trends, personal circumstances, and global events.
 - Examination of pre-pandemic barriers to connection and how they have evolved.
- 5. Discovering Connection in Our Lives**
 - Practical insights into where and how we can foster meaningful connections in daily life.
 - The importance of connections with family, friends, colleagues, neighbours, and strangers.
- 6. The Role of GenWell in Fostering Connection**
 - An introduction to GenWell's mission to improve social health through education, empowerment, and catalytic occasions.
 - Overview of GenWell programs, campaigns, and tools designed to help individuals and communities build connections.
- 7. Q&A and Closing**
 - Open discussion to address participant questions and share stories.
 - Recap of key learnings and available GenWell resources to continue the journey of building connection.

Interactive Discussions and Activities (Integrated Throughout)

- Engaging exercises and discussions are woven throughout the workshop to help participants identify personal and professional opportunities for connection.

Melanie Fougere

From: Melanie.Fougere@townofantigonish.ca
Subject: FW: EXTERNAL: GenWell
Attachments: GenWell Human Connection 101 Workshop Agenda.pdf; GenWell - Town of Antigonish.pdf

From: Emilie Chiasson <[REDACTED]>
Sent: September 8, 2025 1:11 PM
To: Randy Delorey <Randy.Delorey@townofantigonish.ca>
Subject: RE: EXTERNAL: GenWell

Hello!

The cost of having Genwell come here is about \$12,000. I'm working with Elizabeth Yeo on this. She has some money in her budget, so I am hoping to patch together the rest of the money through other departments/groups/funds on campus and the broader community. I've got about \$7500 to cover.

-If you can foresee a special workshop for your employees or combining for a bigger workshop with the community, it would be a bit more of a contribution. \$2000

-If you can't foresee having something for your employees/community than I've been asking for \$1000 to be an event supporter.

Let me know your thoughts!
EC

From: Randy Delorey <Randy.Delorey@townofantigonish.ca>
Sent: Monday, September 8, 2025 10:36 AM
To: Emilie Chiasson <[REDACTED]>
Subject: Re: EXTERNAL: GenWell

Emilie,

Thanks for the note. Just a quick clarification required, you have two distinct requests right?

1. A general sponsorship request - to which I assume relates to covering costs of bringing GenWell to campus; do you have any details on those costs and what you would be looking for in the way of sponsorship?
2. An offer to coordinate a workshop with the Town - which I'm not 100% certain if this is for Town employees (internal) or the Town community (external). And in either case, is there a cost or sponsorship expectation required - would that be inclusive or additive to the general sponsorship request.

Thanks,

Randy Delorey, CAO
Town of Antigonish

[REDACTED]
e. randy.delorey@townofantigonish.ca

From: Emilie Chiasson [REDACTED]
Sent: September 8, 2025 10:14 AM
To: Randy Delorey <randy.delorey@townofantigonish.ca>
Subject: EXTERNAL: GenWell

[REDACTED]

CAUTION: This email originated from outside of the organization. Do not click links or open attachments unless you recognize the sender and know the content is safe.

Hello Randy!

I am super excited to share that [GenWell](#) is coming to StFX campus/Antigonish on October 29th and 30th. I have attached a letter outlining what will be happening during their visit. StFX will be the first university to have a GenWell Day, and I am hoping that Antigonish will be the first town to have a human connection takeover!

I am not sure what your sponsorship/professional development budgets look like, but if you're interested, we could put together a workshop for town and county staff/councils and community groups. If that isn't possible, any support you can offer is appreciated.

If you have any questions, or if you'd like to chat about this – let me know, I'm here to help!
EC

Emilie Chiasson
Manager Annual Giving and Alumni Engagement



I acknowledge that StFX is located in Mi'kma'ki, the ancestral and unceded territory of the Mi'kmaw People.



Request for Financial Support 2025 Paqtnkek Traditional Powwow (Mawi'omi)

Kwe' Community Sponsor/Partner,

On behalf of Paqtnkek Mi'kmaw Nation, we are honoured to share that our community's Traditional Powwow (Mawi'omi) will take place from September 26-28 2025. This sacred gathering, held on our ancestral grounds, is more than a celebration of Mi'kmaq culture it is an act of healing, remembrance, and renewal.

This year's Mawi'omi holds special significance as we continue our community's journey through our "Year of Healing." Together, we are working to address the deep intergenerational wounds caused by colonial policies, residential schools, and systemic trauma. We believe that Mi'kmaw culture shared through our songs, dances, stories, ceremonies, and language is essential medicine in this healing process.

We are reaching out to request a financial contribution or donation to help us host this important event. Your support will help cover the costs of cultural performers, traditional drummers, Elders' honoraria, youth engagement activities, meals for attendees, and ceremonial supplies. Every dollar received will be directed toward ensuring that our community especially our young people can take part in the sacred practices that keep our spirits strong.

Your generosity will not only support a cultural event; it will help bring a community together in strength, pride, and resilience. In the spirit of reconciliation and shared commitment to healing, we invite you to stand with Paqtnkek in making this year's Powwow a meaningful and transformative experience for all.





We would be honoured to acknowledge your contribution during the event and in our promotional materials unless you prefer to remain anonymous.

Wela'liq (thank you) for considering our request. Should you have any questions or require further information, please don't hesitate to contact me directly at 902 872-0762.

With deep gratitude,

Jeremy Paul

Councillor Jeremy Paul
Paqtnkek Mi'kmaw Nation



Subject: CAO Report
To: Antigonish Town Council
Date Prepared: 2025-09-15
Prepared by: Randy Delorey, Chief Administrative Officer

Administration

This report compiles monthly updates and progress reports from the Town of Antigonish’s Administration, AREA Community Development, and Public Works departments.

- Regular meetings with RK Steering Committee (new build)
- REMO – Q2 Planning meeting with stakeholders and Advisory Committee meeting
- Community stakeholder meetings (ie. AWRC – updated on new building; suggested presentation to Council – they did at September CoW meeting).
- Strait-IT Board Meeting – Appointed Chair for 2025-2026
- Provincial funding partner meetings (virtual) (CHIF, GRID, and ICIP projects)
- Finalized Collective Bargaining agreement documents for signatures (EU & PW/Facilities)
- Engagement with community members to secure access for test wells (water source)
- Regular engagement with staff
- Welcomed Co-Op student to Marketing & Communications team for the fall term
- AREA meetings – Solar Garden insurance claim, litigation, and regulatory filing
- Monthly Occupational Health & Safety meeting with staff
- Q3 Helping Healthcare Antigonish board meeting
- Attended Institute of Public Administration of Canada national conference in Halifax.
- Evaluating fit for a term admin / clerk position to support Corporate Services & Community Development directors – a 600 hour work placement funded at 70% by ISANS.

Marketing & Communications Update:

Projects
Title: Net Zero Engagement Strategies
Status Update: Check-in meetings with Forward Creative. Brand audit still underway. They have developed staff and Council surveys that will be implemented shortly once reviewed.
Next Step: On-going
Title: Website Updates
Status Update: <ul style="list-style-type: none"> - Live streamed Council meetings uploaded - I.O.O.F By-Law uploaded - Various contact information updated - Council, COTW, and Committee meetings updated on the Events Calendar - Waste Management Page is being updated with Circular Materials content - Home page banner created for Circular Materials communications
Next Step: on-going
Title: Events

<p>Status Update:</p> <ul style="list-style-type: none"> - Cadets Canada Flag Raising Ceremony request has been received. Once approved by Council, will begin coordinating logistics. - Mini-pitch MLA meet & play attended & photographed
<p>Next Step: on-going</p>
<p>Title: Public Notices</p>
<p>Status Update:</p> <ul style="list-style-type: none"> - Power outages - Splash Pad Vandalism - Street closures - Water conservation notices - Town Hall closures
<p>Next Step: On-going</p>
<p>Title: Advertising and Sponsorship requests</p>
<p>Status Update:</p> <ul style="list-style-type: none"> - Wording & graphic prepared for the Guysborough Journal for Truth and Reconciliation Day
<p>Next Step: n/a</p>
<p>Title: Speaking Remarks and Letters</p>
<ul style="list-style-type: none"> • N/A
<p>Next Step: on-going</p>
<p>Title: Social Media Updates</p>
<p>Status Update:</p> <ul style="list-style-type: none"> • Public notices • Water conservation measures • Community postings • Power updates • StFX, HS, & Elementary Back to School posted • Nuisance Party By-Law, Waste Collection & Noise Control, and Antigonish parking pamphlets redone & posted on socials • Sewer Awareness posted & re-sized into a pamphlet for print • Good Neighbour Guide post created • Miscellaneous
<p>Title: Housing Accelerator Fund Communications Strategy</p>
<p>Status Update:</p> <ul style="list-style-type: none"> • Website launch delayed
<p>Next Step: on-going</p>
<p>Title: Marketing Levy</p>
<p>Status Update:</p> <ul style="list-style-type: none"> - Tracking down payments and remittances - Ongoing meetings with Bethany Collier and Shannon Long to get up to date on remittances and having discussions about how to automate process.

- Personalized Collections email template created & populated with missing forms & payments
- Monthly remittance reminder email template created
- Finance Collections email template created

Next Step: On-going

Title: Co-op Student Recruitment and Onboarding

Status Update:

- Winter 2026 Co-op Student Funding Application Submitted
- Marketing and Communications Co-op Fall 2025 student started last week
- Safety orientation complete
- Getting them up-to-speed on current priorities
- Learning objectives completed & submitted
- Website audit template created & have begun chipping away at website review
- EMO template research & creation has begun; Evacuation Order & Animal Rescue templates complete

Next Step: On-going

Subject: Staff Report
To: Antigonish Town Council
Date Prepared: Sept 9th, 2025
Prepared by: Kyle Meisner, P. Eng., Director of Infrastructure and Engineering

Department of Infrastructure and Engineering

Projects/Tender Update:

Projects
Title: Project Manager Hiring
Status Update: Project Manager (L. Basinger) started July 28 th , 2025
Next Step: Accelerate project work
Title: West / James St Capital Project
Status Update: Survey work complete and design well underway.
Next Steps: Issue RFP for sewer lining portion of the project (Phase 1) Sept 16 th , 2025.
Title: Intermunicipal Agreement (Sewer Flow Study)
Status Update: RFP closed, awarded to RV Anderson
Next Step: Kickoff meeting Aug 13 th 2025
Title: STP Screening / Headworks
Status Update: Screening System Tender Closed Sept
Next Steps: Post Tender for screening equipment supply / purchase
Title: Bay St Municipal Servicing Upgrades Capital Project
Status Update: Negotiations / contract signing progress with property owners, Bell, Railway Draft tender was received, and feedback was provided for edits.
Next Steps: Finalize project stages to issue Phase 1 (Haley Rd to Tracks) tender, Sept 16 th , 2025.
Title: Hwy4 AT/Roundabout Project
Status Update: Project proceeding, detour now in place
Next Step: Strum undertaking inspections of work
Title: Safety Management System
Status Update: Electronic SMS RFP closed Aug 14 th , 2025
Next Step: Assessing for best value and data hosting (US vs Canada)
Title: In-house Sidewalk Capital Works
Status Update: Greening Dr design work completed
Next Steps: Start work to install new sidewalk on Greening Dr. with trees and CBs week of Sept 12th
Title: Source Water Test Wells
Status Update: Q+A underway with targeted property owners for land access
Next Steps: Reach agreements, undertake test well drilling by October
Title: PW Equipment Purchases
Status Update: Loader – Loader Purchase Finalized Service Trucks – Tendered and purchased, 2 nd truck delivered Aug 11 th 2025 Single Axle Salt Truck – Finalizing for award Sept 9 th 2025
Next Steps: Award Salt Truck Tender as soon as possible due to long lead times (40 weeks)

Electric Utility (EU):

Projects
Title: Grid Modernization
Status Update: Substation Transformer Assembly Tender awarded to Siemens June 20 th 2025 Substation Civil Works Tender awarded to R. Chisholm Hydroseeding June 20 th 2025 Substation Steel Structures Tender awarded to Cherubini Aug 5 th 2025 Substation Transformers arrived Sept 8 th , 2025 Distribution Transformer changeouts underway with seasonal PLT hires
Next Steps: Complete switching station design with NSPi for transmission line interconnection
Title: Solar Garden
Status Update: AREA accepted Care and Control of site July 2025 EU Troubleshooting issues with Inverter #3 + #5 and associated breakers
Next Step: Adjust breakers with design engineers, replace if necessary
Title: EU Code of Practice
Status Update: Rubber Gloving Code of Practice submitted to Province for review and approval
Next Step: Complete Provincial review and approval process, begin training
Title: Power Outages
Status Update: Outage completed for NSPi re-installation of grounds + reclosure at Cloverville Substation For maintenance work - short service outages will be required till Code of Practice in place.
Next Step: Continue coordination with Communications on outages
Title: Operations Items
Status Update: Items as noted below
Next Step: Installation of new poles + connections for 127 – 131 College St Development Remove Temp service for affordable housing project Tree trimming work underway Electrical contractors connects and disconnects Street Light replacements Exhibition grounds temporary connections
Title: Break-ins and theft
Status Update: 1 instances of break-in and theft under investigation: - Aug 4 th , theft of copper scrap (TOA), and grounds from NSPi substation
Next Step: Assess for increase in security – additional cameras and fencing

Treatment Facilities:

Projects
Title: Water Plant Pond Desludging
Status Update: Continuing sludge removal from Pond 2.
Next Steps: Continue sludge removal from Pond 2 until drying bed capacity is filled.
Title: Operational Support (Contract)
Status Update: Contracted support underway, accepted March 6 th 2025
Next Step: Continue work on STP Aeration maintenance. Two days with 2 operators remain in contract.
Title: Source Water Review
Status Update: Prepping RFP for negotiation services to secure test well locations
Next Steps: Release RFP for bidding
Title: Replacement of Discharge Pumps
Status Update: Sourcing suppliers for replacement pumps and materials.
Next Steps: Request for Quotations
Title: Sewage Plant Aeration Work
Status Update: Continuing rag removal in Cell 1B & repairs as needed. Replacing header hose as leaks are identified.
Next Steps: Change out or repair any equipment that has air leaks.

Title: Lagoon Aeration Equipment RFP
Status Update: RFP Issued on August 29, 2025.
Next Steps: Closing Date September 19, 2025. Evaluate and award.
Title: Sewage Plant Headworks Pump Installation
Status Update: Refurbished pump installed, and power connected.
Next Steps: Schedule relay installation for alarms on SCADA.
Title: Sewage Plant Filter Cleaning
Status Update: Equipment in place to start cleaning.
Next Step: Start recirculation and cleaning of filter sand.
Title: Recirculation of Sewage Plant Water
Status Update: 3-inch pump recirculating water from line 11 to line 1 continuously. 6-inch pump recirculating water from line 12 to line 2 when staff on site.
Next Step: Continue recirculation of oxygenated water from back of sewage plant to front.
Title: Cold Water Addition to Sewage Plant Headworks
Status Update: Water addition stopped in accordance with water conservation measures.
Next Step: Re-start water addition once water conservation measures are no longer in place.

Public Works (PW):

Personnel

Title: New Public Works Crew

Status Update: A three-person Labourer/Operator crew and one Working Foreman were hired on a six-month temporary term to complete concrete repairs and capital projects in 2025. The existing Working Foreman was promoted to Working Supervisor, and a senior crew member was promoted to Working Foreman to lead the maintenance crew.

Next Step: The new Foreman began on July 29, 2025, and the crew started August 5. Recruitment remains open for two temporary Labourer/Operator positions.

Title: Public Works Students

Status Update: Three students worked from July 2 to August 29. They completed line painting for parking lots and streets, assisted with green bin deliveries, and supported Public Works with traffic control.

Next Step: N/A

Title: Training

Status Update: New Public Works crew members and students completed First Aid and TCP/TWS training.

Next Step: N/A

Title: Voluntary/Mandatory Water Conservation

Status Update: Voluntary water conservation measures were in place from July 17–24 and again beginning July 28, followed by mandatory conservation starting August 6. During this time, Public Works reduced non-essential water use, such as vehicle washing and street sweeping.

Next Step: Public Works continues to prioritize conservation and is developing contingency plans for further drought conditions, including tanker support to supply the plant and pumping from the low-level reservoir if intake levels drop.

Title: Union Contract

Status Update: An agreement was reached with all parties.

Next Step: Contract to be signed.

Fleet/Equipment

Title: New Equipment and Trucks

Status Update: A new Silverado and 14' job trailer were received, and two rental units were added until year-end. An older Public Works truck will be retired at the end of August. A new Komatsu WA320-8 Wheel Loader is expected by the end of September. Quotes for a new single-axle truck are under review (estimated arrival Summer 2026).

Next Step: Review and select the single-axle truck.

Streets

Title: Sidewalk/Curb Repairs

Status Update: A concrete crew was hired to install new sidewalk on Greening Drive; design is now complete. The crew also addressed several known problem areas, including College St./St. Ninian intersection, Mt. Cameron curb repair, and reestablishment of Columbus Field curb. Upcoming projects include the Main Street bulb-out and mid-block relocation.

Next Step: Assess additional areas as work is completed and reinstated.

Title: Line Painting

Status Update: All major intersections were painted by July 25, with line painting completed August 15. Students also painted tactile plates, hydrants, and guardrails.

Next Step: Additional line painting needs will be completed by the Public Works crew.

Title: Mill and Fill Tender

Status Update: Locations identified for mill and fill have been issued for tender, tender closed Aug 28th, 2025.

Next Step: Review, decrease work scope to budget, and award tender.

Wastewater and Storm Water Collections

Title: Sewage Flow Study

Status Update: A sewage flow study is underway with the consultant, including eight monitoring locations and manhole asset data collection.

Next Step: Meet with the consultant to install monitoring equipment.

Title: James / West Street Locates

Status Update: Camera footage was collected for storm and sewer lines near West/Fairview/James Street to assist WSP with redesign of waterline and storm connections.

Next Step: Locates are complete; WSP to finalize road / sidewalk design.
Issue Sewer Lining Tender once approved by Council to proceed.

Water Distribution

Title: Transmission Line Water Break

Status Update: A break on August 5 was temporarily patched the same day, and the plant was back online by 11 p.m. Final repair was completed August 11 once parts arrived.

Next Step: Conduct an inventory review to improve incident response readiness, develop an SOP for handling/disposal of AC pipe, and ensure the transmission line is clearly marked with signage.

Title: Hydrant Repair & Replacement

Status Update: Hydrants were replaced at Pushie Street and Highland Drive, and repairs completed at Cloverville Road and Bantry Lane. The Scarboro hydrant requires specialized repair, scheduled for September.

Next Step: Complete Scarboro hydrant repair.

Title: Leak Detection

Status Update: Ongoing leak detection with a consultant revealed two residential service leaks, both of which have been repaired by homeowners.

Next Step: Continue periodic leak detection investigations on a scheduled basis.

Waste Management:

Projects
Title: Circular Update
Status Update: Turn over recycling pickup to Circular in December 2025
Next Step: Meeting for Communications items Aug 21st
Title: Solid Waste Items
Status Update: Waste Management Bylaw - awaiting Municipal Affairs approval for SOTs
Next steps:
Title: Waste disposal weights – End of July, 2025
Status Update: RWC (July) 333.71 T

Traffic Authority:

Projects
Title: Parade / Road Race / Street Fair Permits
Status Update: Assessing for Antigonight Permits
Next Step: Create Policy for parade requirements for clarity for 2026 (winter)
Title: Crosswalk Changes
Status Update: Work underway for changes to crosswalks at Acadia St / Main and Library / Main Crosswalk moved at St Ninian's / College
Next steps: Plan to consolidate to one crosswalk at Shoppers as per WSP assessment report



Kyle Meisner, P.Eng.
Director of Infrastructure and Engineering

Subject: Community Development Council Report
CAO Report
To: Antigonish Town Council
Date Prepared: September 9, 2025
Prepared by: Shannon Long, Acting Director of Community Development

Community Development

Division Updates:

By-Law
<p>Case Management System and Parking Tickets: By-Law Officers have begun using the new system, Breken, for case management. Staff still need some training (including the reporting features) but there are 17 active case files open. By-Law Officers and StFX Security are still using issuing paper parking tickets as staff continue to work with Breken to get new system configured to our parking rates, parking violations, printers, etc. To date, over 90 parking tickets have been issued since mid-July.</p>
Parks & Recreation
<p>Summer Camps: The Town hosted seven weeks of summer camps this year and they all went smoothly thanks to an excellent summer camp staff. Post-camp surveys were sent to parents of the campers and there were some glowing reviews submitted.</p> <p>Multi-Sport (kids): The 2025-2026 program starts in September and continues twice weekly until April 2026. The goal of the program is to give children a quality, first-hand experience with nine different sports. Registration took place on August 20, 2025. All 60 spots have been filled and there is a wait list.</p> <p>Multi-Sport (adults): The Town has launched a multi-sport program for adults. Adults will have the opportunity to learn four sports (beach volleyball, stand-up paddleboarding, tennis, and golf) over four weeks. Registration was on September 3 and all 20 spots have been filled.</p> <p>Moving & Mingling: Following a very successful pilot year, the Town, in partnership with the Municipality of the County of Antigonish, will once again be offering the Moving & Mingling program with a tentative launch of early October. Details are being finalized including verifying the locations taking part this year and moving to an online registration process.</p> <p>Registration Platform: In partnership with the Municipality of the County of Antigonish, a request for proposals was issued for a new registration platform to replace Sport Hub. The deadline for submissions was Friday, August 8. Town and County staff have met to evaluate the three proposals that were submitted by the deadline and hope to meet again this week to make a final decision.</p> <p>Cameras - Columbus Field Washrooms: Staff are working with Strait-It to determine the best option and placement of a camera for the washroom building.</p> <p>Splash Pad: A request for quotes was issued for a qualified engineering firm to assess the splash pad to identify any structural or infrastructure-related concerns and provide actionable recommendations to address drainage, water pressure, and observed settling or sinking issues. Strait Engineering was the successful proponent and is now working on the assessment.</p>

On Friday, September 5, one of the doors to the control panel for the splash pad was vandalised (pulled back) so someone had access to the valves and switches. Water to the pad had to be turned off so the pad was out of commission for the weekend. Staff are working with a contractor to get the door fixed but with the cooler weather the splash pad may be off for the rest of the year.

Storage: A new storage container (sea can) was approved in the 2025-2026 budget for parks and recreation. Staff are looking at locations and sizes and will soon be issuing a request for quotes to secure one.

Parks and Maintenance Staff:

Two of the four Parks and Maintenance staff officially wrapped up their summer term at the end of August but have since come back to assist with cutting the grass/weeds at the solar farm with assistance from the Public Works summer staff. Staff received safety orientations last week and begun cutting on Friday and have made great progress.

Department Updates:

Tourism
A job description for a Tourism Officer was posted and interviews were done on August 20, 2025. After careful consideration, the hiring committee offered the position to Mikaela Williams who has accepted and will start work on October 1 in her new role.
Good Neighbour Committee
The sub-committee of the Good Neighbour Committee to discuss St. Patrick’s Day took a break over the summer. There is a meeting scheduled for next week.
The Good Neighbour Committee met in early September. Move in weekend went smoothly and plans are coming together for Homecoming with over 400 alumni registered. The Town was able to supply materials for the welcome packages being distributed at the house calls including information on the Nuisance Party By-Law, sorting waste, parking, and the Noise Control By-Law.
Mural Program
The Town will once again be working with Antigonish Culture Alive to add a new mural in 2026. Potential locations are being identified and terms are being finalized to accept proposals this Fall.

2025/2026 Project Updates:

Town Hall Lighting
Air Energy Solutions was chosen as the vendor to install five lights around the second storey of the Town Hall Clock Tower. The intent is to have them installed by this month.
Accessible Pathways –Phase Two (2025)
Phase Two of the pathway project is to pick up where the pathway ends at the Sandlot. This pathway will travel the length of the Central Turf Field to the bleachers and will also include a paved viewing area. A Request for Proposals for the design of the pathway has released and WSP was selected. WSP has completed survey work and designs should be submitted to staff today for review so a construction tender can be issued this month. Provincial and federal funding deadlines are mid-December.

Fence at Columbus Field
The Town has committed to replacing a fence at Columbus Field that had to be removed for infrastructure work. The fence will separate the field from the businesses on St. Andrew’s Street. This fencing project will be part of the Request for Proposals that Infrastructure will be preparing for new fence to help with costs.
Active Transportation Trail
The Knights of Columbus have reached out and requested a site visit with staff and WSP to discuss the design through Columbus Field. Staff are working on confirming a date for early October.

Housing Accelerator Fund Updates:

High-Density Zones
A Planning Advisory Committee will need to be scheduled in September for the consultants from Upland Planning and Design to present the recommended changes to the Land-Use By-Law. Upland is also prepared to launch a community engagement process with an online survey and will be reaching out to stakeholders for feedback.
Modernization of the Permitting Process
The portal is under development for the new permitting process.
Source Water Protection
Staff are working to establish agreements with property owners and are aiming to have a preliminary draft request for proposals for drilling services completed this week. The intent is to be drilling by end of October.
Town Services Grant
Town council approved a new Town Services Grant in June. The Town and County would like to launch their grants at the same time; the communications team will be assisting with the marketing materials and website content.
Community Transit
Antigonish Community Transit continues to work with Happy Cities on the design of their new route.

Subject: CAO Report
To: Antigonish Town Council
Date Prepared: September 09, 2025
Prepared by: Meaghan Barkhouse, Director of Corporate Services

Corporate Services

Highlights

September is traditionally one of the busiest months at the front counter, with increased activity related to electric contract connections and disconnections as students return to Antigonish and update their lease information with the electric utility.

In addition to this operational demand, five key financial reports are scheduled for submission to the Province in September:

- Capital Investment Plan (CIP);
- Statement of Estimates – Assessment (SOE A);
- Statement of Estimates – Budget (SOE B);
- Town of Antigonish Council and CAO expense reports (April 1, 2025, to June 30, 2025);
- Financial Information Reporting (FIR); and
- Approved Audited Financial Statement.

Corporate Services is on track to file the CIP, SOE-A, SOE-B, and Council/CAO expense reports this month. Completion of the FIR is contingent on the finalized audited financial statements and typically requires up to two weeks to prepare once those statements are received.

While a more detailed audit update is provided below, Corporate Services notes with regret that the audited financial statements will not be finalized by the September 30th deadline. However, the process remains on track for completion this fall, with a more precise timeline expected following the auditors’ review next week.

Department Update:

Projects
Title: 2024-25 Year End Audit
The auditors, MNP, are scheduled to be on-site at Town Hall during the week of September 15. The Manager of Accounting and the Accounting Clerk have been proactively providing the requested supporting documentation to ensure the auditors’ time in Antigonish is used as efficiently as possible. Despite these efforts, the current pace of the audit indicates that the September 30 provincial filing deadline for the financial statements will not be met.
Next Step: On-going
Title: Collective Bargaining – Public Works & Treatment Facilities
Council endorsed the proposed Public Works & Treatment Facilities Collective Bargaining Agreement (CBA) at the August 18 Council meeting. On August 25, Town members of the I.B.E.W., Local 1928 voted in support of the proposed contract. The contract is currently being prepared between the Town’s legal and the Union administration with a signing to be completely shortly.
Next Step: Have the agreed contracted formally updated, and signed by the Town and Mayor, and the I.B.E.W., 1928 Business Manager and Shop Steward.

Title: Preventing Workplace Harassment

Effective September 1, 2025, new Workplace Harassment Regulations came into force in Nova Scotia under the Stronger Workplaces for Nova Scotia Act. Earlier this month, Corporate Services had the Preventing Workplace Harassment subsection for the Human Resources Standard Operating Procedures (SOPs) updated to meet the new requirements. This included language and definitions updates, enhances clarity on the investigation process and added a training section.

Next Step: Update HR Manual and plan training requirements for staff.

Title: Human Resources

Employee Hiring and Attrition

- The following positions are open with applications being accepted:
 - Equipment Operator/Labourer – Term
- The Communications and Engineering co-op student began in their terms at the beginning of September.
- The Marketing and Communications Officer has sent in their resignation with an end date of Tuesday, September 30th. As this position was being filled as a maternity term, it has been evaluated if it will not be backed filled for the remaining four months remaining

Work Placement Opportunity

The Town of Antigonish was approached by ISANS (Immigrant Services Association of Nova Scotia) regarding a possible work placement. This candidate is looking for a placement in Antigonish and is looking to gain administrative experience as she has a goal of receiving an NSCC Diploma in Administration. The program would cover 70% of all wages and mandatory employer related costs (MERC – employment insurance, Canadian Pension Plan, etc.) up to minimum wage. A business case is being prepared for the CAO to review.

Next Step: On-going

Title: By-Law for Partial Exemption of Lands of I.O.O.F (Independent Order of Odd Fellows)

A letter has been prepared and sent to the property owner of the building related to the By-Law for Partial Exemption of Lands of I.O.O.F. (passed in 1981). Town staff reviewed this bylaw and discovered that the reduction of commercial tax rate to residential rate is only for the portion of property that is used and occupied by the I.O.O.F.; not 100% of the property. The Town will require an annual notarized attestation stating what percentage of the property would fall under this provision, where the Town has prepared a attestation form template. A copy of the 1981 IOOOF bylaw can be found on Town of Antigonish website ([link](#)).

Next Step: Receive the attestation in 2026 for the 2026-27 budget

Title: Electric Utility – Nova Scotia Energy Board

The Town was named and in a complaint to the Nova Scotia Energy Board (former Nova Scotia Utility and Review Board), regarding the Town’s regulations for disconnections for non-payment or “involuntary disconnection”. This complaint has been since withdrawn.

The involuntary disconnection of a customer is never an easy decision, nor one this office takes lightly. The concern was in regard to not being able to enter a payment plan as service was already disconnected. A key component is that once disconnection for non-payment occurs, reconnection can not occur until payment has been made in full (and if the deposit has been applied to the arrear balance, a new 3-month bill deposit must be paid first). Payment plans are encouraged and offered to customers who are in arrears and reach out the Town before involuntary disconnection occurs.

The appeal has been withdrawn by the resident; if there is any further action required by the Board, Council will be kept apprised.

Next Step: No action required at this time

Title: Professional Development
The Director of Corporate Services and Manager of Accounting will be at the Association of Municipal Administrators of Nova Scotia (AMANS) Fall conference September 23-26 They will be attending a session specific for Municipal Finance Officers on September 23rd (Embedding Risk into Municipal Finance: Tools, Controls, and Governance – A Hands-on Workshop for Finance Leaders) as well as other sessions with municipal finance officers and other administrators from across the province. This conference contributes to the annual professional development requirements that CPA Nova Scotia (Chartered Professional Accounts of Nova Scotia) requires to maintain the CPA designation. (CPAs are required to obtain 120 hours of professional development over a rolling three years total, with a minimal of 4 hours of ethics during this time and a minimum of 20 verifiable hours per year.)
Next Step: Attend AMANS Fall conference from September 23 to 26 th .
Title: Equity, Diversity, and Inclusion in the Workplace
This project was on temporary pause, the Director of Corporate Service is in progress of re-connecting to our consultants to have the report presented to Council. Developing and implanting an Equity, Diversity, and Inclusion (EDI) policy in the workplace is one of the accords Council signed with when the Town began applying for funding related to the grid modernization funding. The Directors of Corporate Services and Community Development, and the Strategic Projects Coordinator have received a working draft of the consultant’s report on EDI for Town of Antigonish, which has come with recommendations and steps to make improvements within the workplace. This is being reviewed for comment and will be presented to Council over the coming month.
Next Step: Consultants Report to be presented
Title: Work from Home Policy
Corporate Services has finalized a draft Work from Home (WFH) policy that is ready for internal review. It has included potential strategies that other similar Town municipalities have implemented, including the Town of Bridgewater.
Next Step: Finalize and present to Council regarding a Work from Home Policy.
Title: In Development: Charitable Donation Policy
Status Update: Corporate Services has prepared a charitable donation policy for the Town of Antigonish. This would formalize the charitable donation receipt program and outline the standards for evaluating donations in accordance with Canadian Revenue Agency (CRA) guidelines. This is in the review stage.
Next Step: Finalize and prepare a memo to Council regarding a Charitable Donation Policy.

March 2025 Financial Statements will be available after the year-end audit is completed.

Grants to Organizations/Council Discretionary Account Listing (as of September 9, 2025):

Committed: \$167,026.99
 Budget: \$200,000.00
Remaining: \$ 32,973.01

Committed:

Vendor	Description	Amount
DR JOHN HUGH GILLIS REG HIGH S	Dr JH Gillis-Mod Unite	\$300.00
ANTIGONISH JR B BULLDOGS	Don Johnsons Cup	\$2,000.00
DR JH GILLIS REGIONAL HIGH	St Marth's Relay	\$200.00
ANTIGONISH COUNTY ADULT LEARNI	ACALA-'25 Comm Grants	\$3,500.00

THE TOWN OF
ANTIGONISH

ANTIGONISH AFFORDABLE HOUSING	Ant Afford Hsing-'25 C	\$4,500.00
ANTIGONISH ART FAIR &	Art Fair-'25 Comm Gran	\$18,000.00
ANTIGONISH CHALLENGER BASEBALL	Ant Chall Baseball-'25	\$2,000.00
ANTIGONISH CULTURE ALIVE	Ant Cult Alive-'25 Com	\$6,500.00
ANTIGONISH EMERGENCY FUEL FUND	Ant Emer Fuel-'25 Comm	\$5,000.00
ANTIGONISH HIGHLAND SOCIETY	Ant Highland Soc-'25 C	\$15,000.00
ANTIGONISH IMAGINATION LIBRARY	ABC for Kids-'25 Comm	\$6,500.00
ANTIGONISH SENIORS CARE VAN	Ant Sr's Care Van-'25	\$1,000.00
ANTIGONISH SKATE PARK ASSOCIAT	Ant Skateboard-'25 Com	\$2,000.00
ANTIGONISH TOURISM ASSOCIATION	Ant Tourism Asn-'25 Co	\$8,000.00
ANTIGONISH VISITOR INFORMATION	Ant VIC-'25 Comm Grant	\$6,000.00
ANTIGONISH FARMER'S MARKET ASSOC	Ant Farmer's Mark-'25	\$2,000.00
ANTIGONISH SNO DOGS	Ant Sno Dogs-'25 Comm	\$15,000.00
ALL-OF-US SOCIETY FOR ART PRES	All-Of-Us-'25 Comm Gra	\$1,500.00
CANADIAN ASSN FOR COMMUNITY LI	CACL-'25 Comm Grant	\$8,000.00
DESTINATION EASTERN AND NORTHU	DEANS-'25 Comm Grant	\$8,000.00
FESTIVAL ANTIGONISH	Fest Ant-'25 Comm Gran	\$15,000.00
KEEP WELL ANTIGONISH	Keep Well-'25 Comm Gra	\$3,000.00
POSITIVE ACTION FOR KEPPOCH	Pos Act for Kepp-'25 C	\$10,000.00
L'ARCHE ANTIGONISH	L'Arche-'25 Comm Grant	\$3,500.00
NAOMI SOCIETY	Naomi Soc-'25 Comm Gra	\$3,000.00
ROOF OVER YOUR HEAD	Roof over Head-'25 Com	\$2,000.00
STRAIT AREA GROUND SEARCH AND	SAGSR-'25 Comm Grant	\$2,500.00
PICTOU ANTIGONISH REG. LIBRARY	PARL-'25 Comm Grant	\$2,900.00
IOOF Property Tax By-law	Move Council Credit IOOF	\$1,976.00
ROSS SCREENPRINT	Canada Day-Council Shirts	\$205.32
EASTERN NOVA SCOTIA EXHIBITION	ENSE	\$500.00
HOW CLUB AA	How Club-Funding-(Taxe	\$945.67
GUYSBOROUGH EMANCIPATION	Guys Emancipation	\$500.00
SETTLEMENT IN ANTIGONISH FOR	2025/26-SAFE	\$6,000.00

	2025	2025	2024	2024
	<i>Budget</i>	<i>Actual</i>	<i>Budget</i>	<i>Actual</i>
Revenue				
Taxes	9,267,538	8,973,341	7,931,983	7,804,890
Grants in Lieu of Taxes	1,338,567	67,233	1,206,255	7,719
Sale of Services	1,380,491	353,056	1,058,889	283,792
Services provided to other governments	1,138,847		397,903	40,919
Other revenue from own sources	269,491	86,826	137,095	209,430
Unconditional Transfers from other governments	691,194	111,241	204,039	111,234
Other Transfers	4,098,460		2,125,770	
	\$ 18,184,588	\$ 9,591,697	\$13,061,934	\$8,457,984
Expenditure				
Mayor and Council	463,427	265,480	460,844	258,091
Corporate Services and Office of the CAO	1,106,198	834,119	933,010	372,692
Capital Account	6,243,832	-	2,513,576	-
Engineering and Public Works	1,666,945	692,604	1,462,376	483,359
Environmental Health Services	1,509,984	474,406	1,353,886	563,782
Community Development Administration	235,493	160,289	479,479	212,816
Partnerships & Initiatives	899,713	161,305	499,701	538,542
Protective Services	3,269,511	661,829	2,960,477	704,334
Recreation and Cultural Services	682,594	294,737	706,221	377,736
Provincial Responsibilities	1,806,818	756,075	1,692,328	708,372
Restructure Account (new)	299,636	-	-	-
	\$ 18,184,151	\$ 4,300,846	\$13,061,900	\$4,219,724
Excess(deficiency) of revenue over expenditur	\$ 438	\$ 5,290,851	\$ 34	\$4,238,260