

**MEETING:** Special Town Council Meeting

**DATE:** July 25, 2025

**TIME:** 3:30 PM

**PLACE:** Town Council Chambers

---

## Agenda

1. **Call to Order**
  2. **Approval of Agenda**
  3. **Sponsorship/ Financial Requests**
    - 3.1 Arm Wrestling National Championships – Gary Kell
    - 3.2 Team Nova Scotia, Women’s Soccer (Canada Games Nationals) – Sadie Delorey
    - 3.3 Eastern Nova Scotia Exhibition – Financial Request
    - 3.4 2025 Emancipation Celebrations - Financial Request
    - 3.5 Knights of Columbus / HOW Club – Financial Request
  4. **New Business**
    - 4.1 Sewer Treatment Plant Odor
    - 4.2 Water Conservation (Splash Pad & Flower Watering)
  5. **Adjournment**
- 

**To:** Business community of Antigonish and Friends  
**Fr:** Garry Kell, 10 x Canadian Arm-Wrestling Champion  
**Re:** Request for support, attending Canadian Championships, Regina Sask. July 4 to 7.  
**Date:** June 24, 2025

---

Dear friends,

I am once again representing Antigonish and Team Nova Scotia at the Canadian Arm-Wrestling Championships. I compete in the Para-Challenge Class. I have to date in this category 10 National Championships! I am proud to represent Antigonish every year at this event.

Total cost for my trip is \$2,500. My family and I have invested approx... \$1,600. I have an request into the Town of Antigonish and am trying to raise the remaining amount.

Thanks everyone for your assistance over the years!

I truly appreciate!

Garry Kell

10x Canadian Champ





February 2025

**Dear Potential Donor,**

**Re: 2025 Nova Scotia Girls' Canada Games Soccer Team – Donation Request**

We are pleased to announce that the 2025 Nova Scotia Girls' Canada Games Soccer Team has earned the opportunity to represent our province at the 2025 Canada Games in St. John's, Newfoundland and Labrador, from August 19-24. The team is excited to showcase their skills and proudly represent Nova Scotia on the national stage.

In preparation for the Games, the athletes are committed to an intensive training schedule, which includes participation in international tournaments in Florida and the UK. These preparations are essential to ensuring the team is at their best when the Games begin.

To help cover the costs associated with this rigorous training schedule and the team's trip to St. John's, we are seeking corporate sponsorships and donations. Our goal is to raise \$30,000 to support the team's needs, and we would be deeply grateful for your contribution. With the event just around the corner, any support you can provide will make a meaningful impact on the team's journey. We will gladly share your support via our social media.

If you have any questions or are interested in contributing, please feel free to contact the fundraising committee or team manager, Jared Griffiths, at [nscgwomenssoccer@gmail.com](mailto:nscgwomenssoccer@gmail.com) or 902-880-0046 (Jared Griffiths - Cell).

On behalf of the team and Soccer Nova Scotia, we sincerely thank you for your generosity and support of both our athletes and the broader Nova Scotia soccer community.

A handwritten signature in black ink, appearing to read "M. Holton", is positioned above the text "Best Regards,".

Best Regards,

A handwritten signature in black ink, appearing to read "J. Griffiths", is positioned above the text "Jared Griffiths" and "Team Manager".

Matt Holton  
Director of Performance

Jared Griffiths  
Team Manager

## Melanie Fougere

---

**From:** Melanie.Fougere@townofantigonish.ca  
**Subject:** EXTERNAL: EXHIBITION FINANCIAL SUPPORT  
**Attachments:** Fwd: Nova Scotia Exhibition Program- Signature Required

---

**From:** Town of Antigonish Mayor <mayor@townofantigonish.ca>  
**Sent:** July 14, 2025 5:26 PM  
**To:** Leon MacLellan <leon.maclellan@townofantigonish.ca>; Patrick McKenna <patrick.mckenna@townofantigonish.ca>; Jack Sullivan <jack.sullivan@townofantigonish.ca>; Diane Roberts <Diane.Roberts@townofantigonish.ca>; Juanita Pelly <juanita.pelly@townofantigonish.ca>; Andrew Murray <Andrew.Murray@townofantigonish.ca>  
**Cc:** Randy Delorey <Randy.Delorey@townofantigonish.ca>; Melanie Fougere <Melanie.Fougere@townofantigonish.ca>  
**Subject:** Fw: EXTERNAL: EXHIBITION FINANCIAL SUPPORT

---

**From:** Eastern Nova Scotia Exhibition <easternnovascotiaexhibition@gmail.com>  
**Sent:** Monday, July 14, 2025 3:21:04 PM  
**To:** Town of Antigonish Mayor <mayor@townofantigonish.ca>  
**Cc:** Bruce Sinclair <[REDACTED]>; Donnie MacInnis <[REDACTED]>; Jordan Vosman <[REDACTED]>  
**Subject:** EXTERNAL: EXHIBITION FINANCIAL SUPPORT

CAUTION: This email originated from outside of the organization. Do not click links or open attachments unless you recognize the sender and know the content is safe.

Mayor Cameron:

Thank you for taking my call this afternoon as it relates to financial support for the 159th edition of the Eastern Nova Scotia -Exhibition. -

As mentioned, in the past the Town and the County co-sponsored an ad in the Exhibition booklets, however because of printing costs we have decided not to print the book this year because of the increasing costs, and because of this the board agreed to build a website where we will list our sponsors, and we will also post a list of sponsors on the pocket schedules that will be passed out to all patrons as they enter the grounds.

This year we (as well as a few other exhibitions) on short notice found out that our midway operator of over 25 years was closing its operation leaving us to scramble to find some sort of replacement.

The closure of Hinchey's Amusements is going to be a significant financial blow to the Ex this year, not only at the gate but the loss of revenue from their rental space.

With little to nothing compatibly available to replace Hinchey's, we came to an agreement to secure the PEI Carnival Company who are bringing in a much smaller operation that focuses on the younger

children which we believe will affect our gate receipts as well! So, this year sponsorship is important more than ever for the success of the Ex!

What we are requesting from the Town of Antigonish a donation or sponsorship in the amount of \$1,000.00. We have received confirmation from the Municipality of the County of Antigonish for a \$500.00 donation, and \$500.00 in kind which will cover the disposal of waste disposal.

Just on a side note, the Eastern Nova Scotia Exhibition also receives from the exhibition the cost for lights and water consumption that is used in conjunction with the exhibition!

This office thanks you in advance for your consideration on this request.

Regards

Shaun Smith  
Exhibition Organizing Committee





**Upper Big Tracadie Seniors Action Club  
309 Upper Big Tracadie Road  
Monastery, NS  
BOH 1W0**

Sean Cameron, Mayor  
Town of Antigonish  
274 Main Street  
Antigonish, NS  
B2G 2C4

July 8th, 2025

Dear Mayor:

Our organization which has been in effect since 2012, and our mandate and mission statement is as follows: “to educate and promote awareness to seniors of African descent. To instill spiritual and physical well-being through Afrocentric learning. To identify and appreciate their rich and historical culture while being active and inclusive.”

Since the official government approval of the Emancipation Holiday in Nova Scotia, our organization has been celebrating this occasion in the Guysborough District with the assistance of others who understand and know the importance of equity, diversity, inclusion and accessibility.

This year’s celebration, we would like to include the inaugural gala to highlight the week-long events which the planning committee has scheduled for young and old. Our events include sharing, teaching and learning for young and old. There will be fun and entertaining events for those to enjoy as well; something for everyone. We are looking at an estimated budget for the week-long events of \$10,000.00.

We are looking for donations and sponsors. For our corporate sponsors, we will be showcasing a video list of our sponsors throughout the dinner and dance event, providing complimentary advertising. If you would like to be part of the momentous event, please make your donation payable to the following:

**Guysborough Emancipation  
10 Drysdale Place  
Guysborough, NS  
B0H 1N0**

We would like to thank you in advance for your time and consideration in this matter. Also, if you could send along your business logo for the video display, it would be greatly appreciated. If you need any further information, you may contact me at [REDACTED] or email:

[REDACTED]

Yours sincerely,

*Mary Desmond*

Mary Desmond, Secretary - UBTSAC

# Sewer / Water Update

---

Department of Infrastructure and Engineering

July 25<sup>th</sup>, 2025



# Sewage Treatment Plant

---



# Odor Issue - 2025

- Odor started this year around July 1<sup>st</sup>, 2025, approximately the same time as the heat waves started.
- While noticeable, it has not been as pronounced as last year.
- Where it is detectable can vary based on wind patterns, temperature and air pressure.

# Temperature vs Oxygen Levels

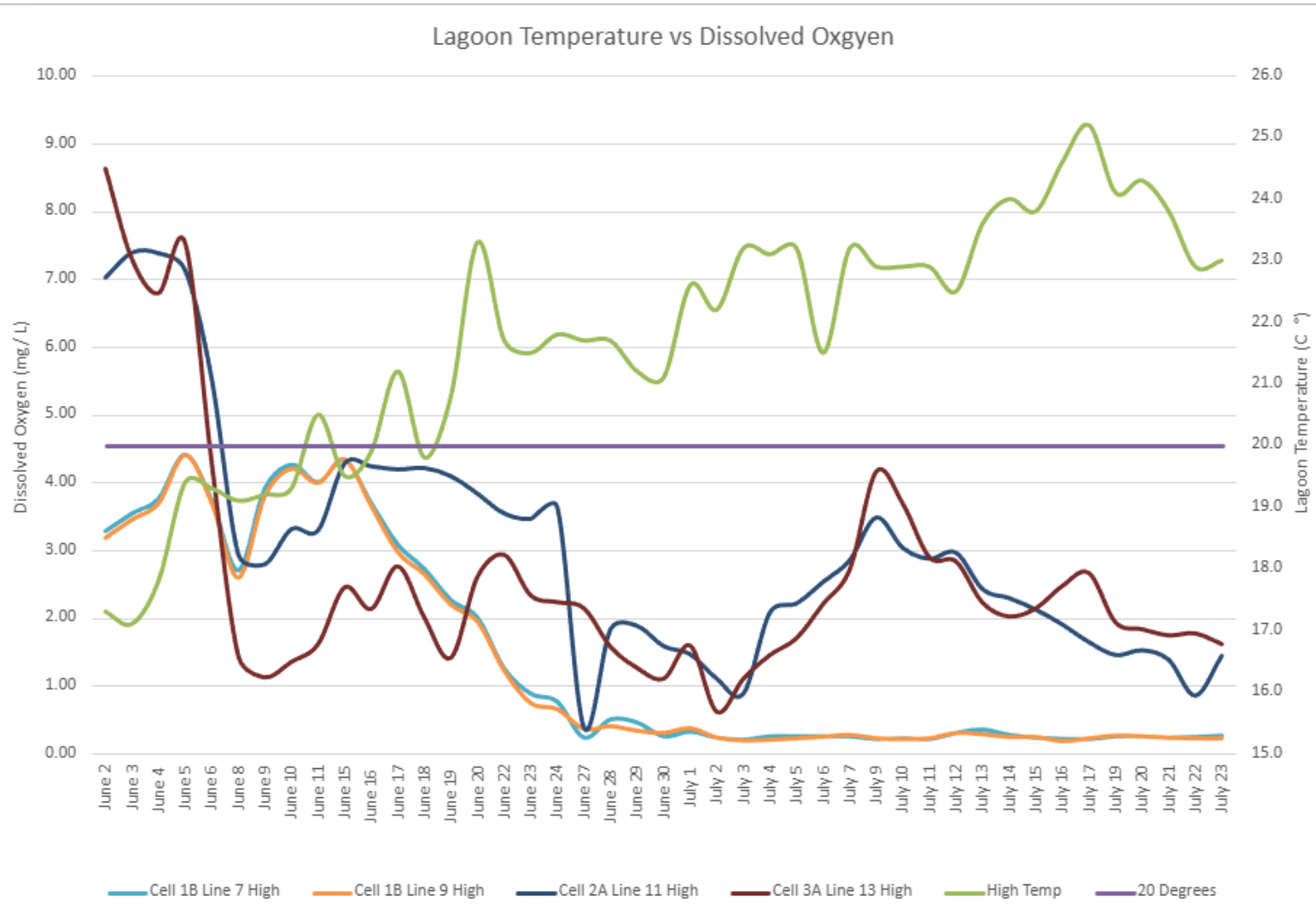

- Once lagoon temperature passed the 20 degrees threshold, oxygen levels dropped in the front end of the plant.
- As per CBCL, the plant was originally designed around a lagoon temp of 20C.
- The back half of the plant has maintained its oxygen levels, but smell comes from the front of the plant where there is less oxygen.
- Primary factor for lack of oxygen is temperature.

# Odor Mitigation

- As per the CBCL report (2024), there were 7 main actions to mitigate the of the lack of oxygen:
  1. Recirculate plant flow from back (high O<sub>2</sub>) to front (low O<sub>2</sub>)
    - Has been underway using existing infrastructure, but work underway to increase flow dramatically with aboveground pumping system – comes with risks.
  2. Increase airflow from existing blowers
    - Blowers back-pressuring, system maxed out and unable to take more air.
  3. Remove Sludge
    - Completed January 2025, see next slides for photos.
  4. Add new Temporary Air Supply
    - Design work underway to undertake this option. Air sizing required spec'd out by CBCL.

# Odor Mitigation (part 2)

- As per the CBCL report (2024), there were 7 main actions to mitigate the of the lack of oxygen:
  5. Redirect influent to Cell 2
    - Carries extreme risks of loss of process and plant quality (which is currently compliant and producing good effluent).
  6. Install influent screening system
    - Design underway with CBCL, tendering expected to start in August with equipment pre-purchases.
    - Building in additional aeration at front end as part of work.
  7. Upgrade Aeration System
    - Designing upgrades with CBCL as part of screening project.
    - Have budgetary allowances to undertake some work this summer.

# Additional Mitigation Measures

---

- **Addition of cold water to lagoon:**

- In an effort to help decrease temperatures and boost oxygen, a system was set up to add cold water to the lagoon safely through the recirculation system, via a fire hydrant.
- This was run for only a few days then discontinued with Water Conservation Measures. As conservation measures have ended, we have begun adding cold water again this week.
- All water is metered and backflow protected for safety.

- **Addition of de-odorizer:**

- De-odorizer has been applied in areas of concentrated odor to help neutralize at the source.
- Particularly, there is a plug of strong-smelling wastewater moving through the plant from the start of the odor issue (possibly high concentration load), and it is approximately 2/3 of the way through the lagoon now.
- Lagoon has a residence time of approximately 30-40 days under current flow levels.

- **De-ragging of aeration equipment:**

- Significant work has been done this year to remove rags and debris from the aeration system manually (as we have no screening system currently)



# Desludging Results

Before Desludging (2022)

CELL 1 – SLUDGE BLANKET THICKNESS

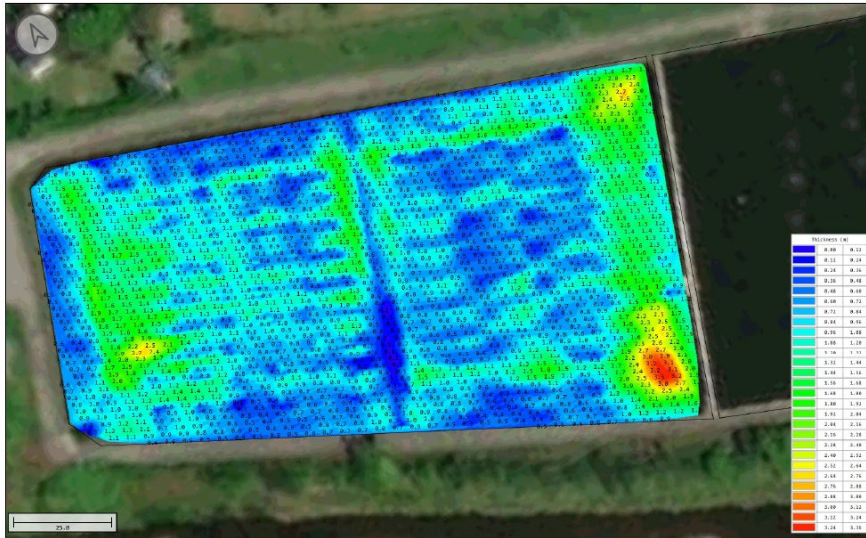

Figure 5 Cell 1 sludge blanket thickness (m)

Approximately 2m of sludge removed across Cell 1

After Desludging (2025)

CELL 1A/B – SLUDGE BLANKET THICKNESS

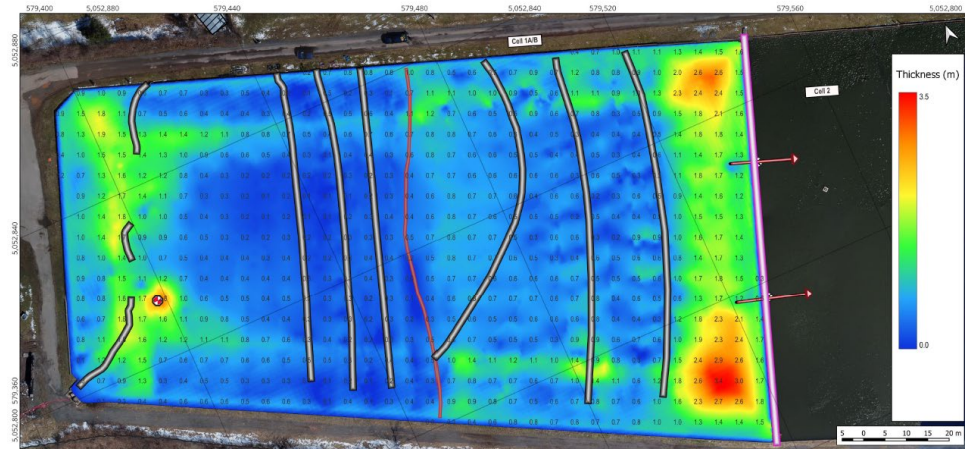

Figure 5 Cell 1A/B sludge blanket thickness

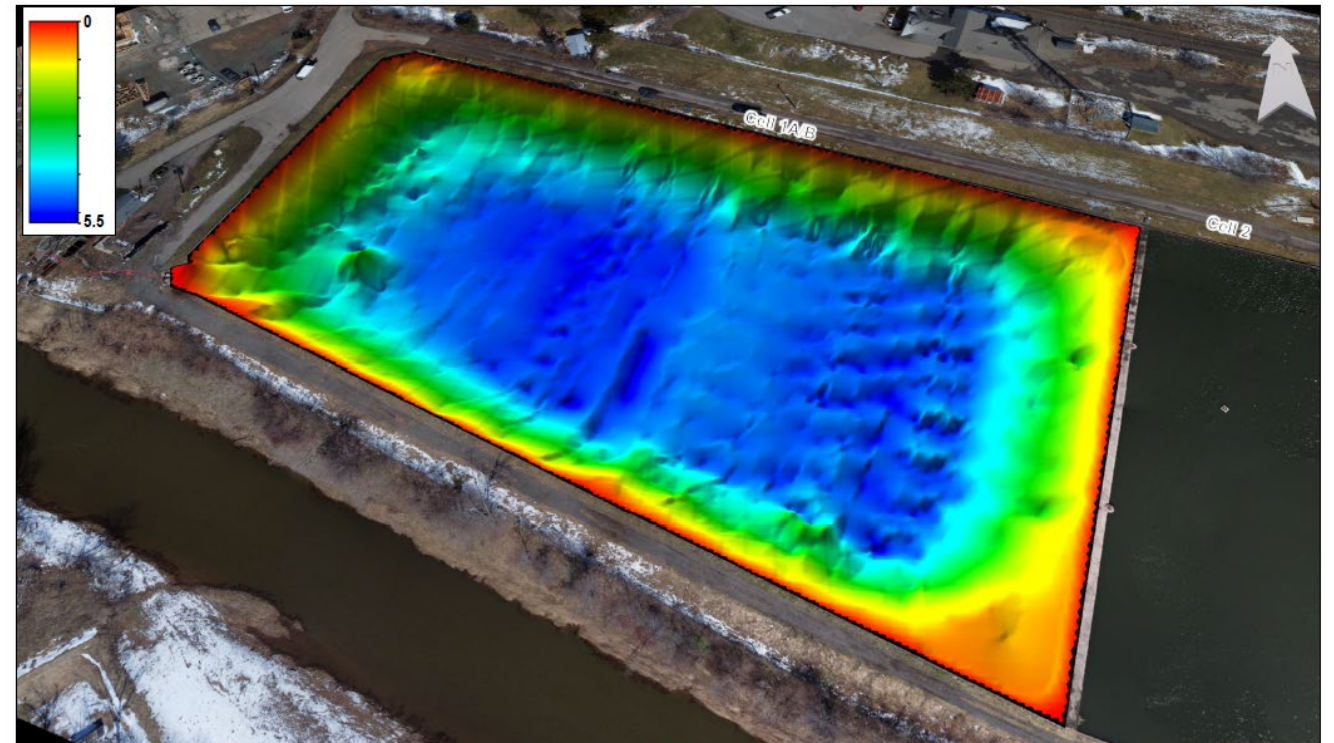

Figure 11 Cell 1A/B top of sludge 3D isometric drawing – south to north

# STP Screening Project

- Design is progressing, awaiting confirmation of geotechnical work.
- Design parameters accounting for future growth over 25 years have been set, equipment pre-order tenders should be going out in 2 weeks.
- Screen loading and lagoon oxygen requirements have been assessed based on this 25-year projection and are being sized accordingly.
- Design is assessing aeration upgrades as well, and the following is proposed (as an example for scale) to meet the future demand:

Cell	Aeration per Cell (SCFM)		Difference
	Existing	Future	
1A	635	1,120	485
1B	530	560	30
2A	318	280	-38
2B	141	168	27
3A	53	112	59
3B	18	84	66
<b>TOTAL</b>	<b>1,695</b>	<b>2,324</b>	<b>629</b>

# Screening / Blower Building Concept

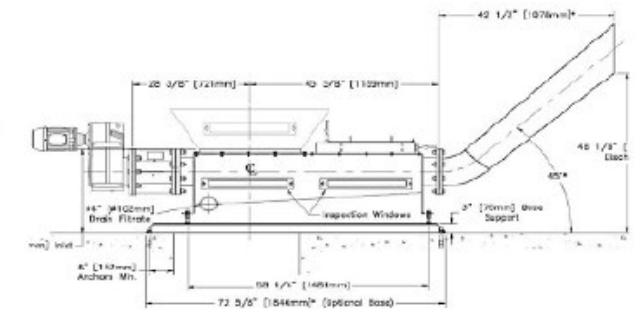
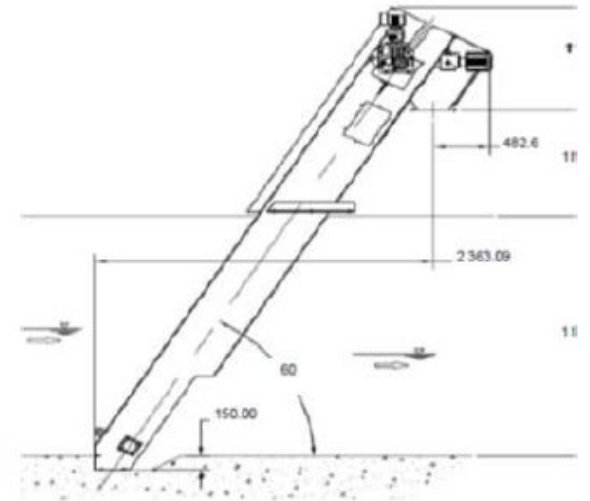

# Sewage Flow Study – Intermunicipal Agreement

- PCAP funding obtained to do a joint study as per discussions at Council and Joint Council.
- RFP tendered for Flow Study services, Closed July 18<sup>th</sup>. Results under review, expected award next week.
- Options have come in on budget (~\$200k) for a 12-month study period to determine flow split between Town and County, and undertake analysis.
- Available Funding:
  - 50% PCAP
  - 25% TOA
  - 25% County
- At the County Council Meeting earlier this week, discussions were had on building their own Sewage Treatment Plant for the Fringe Area.

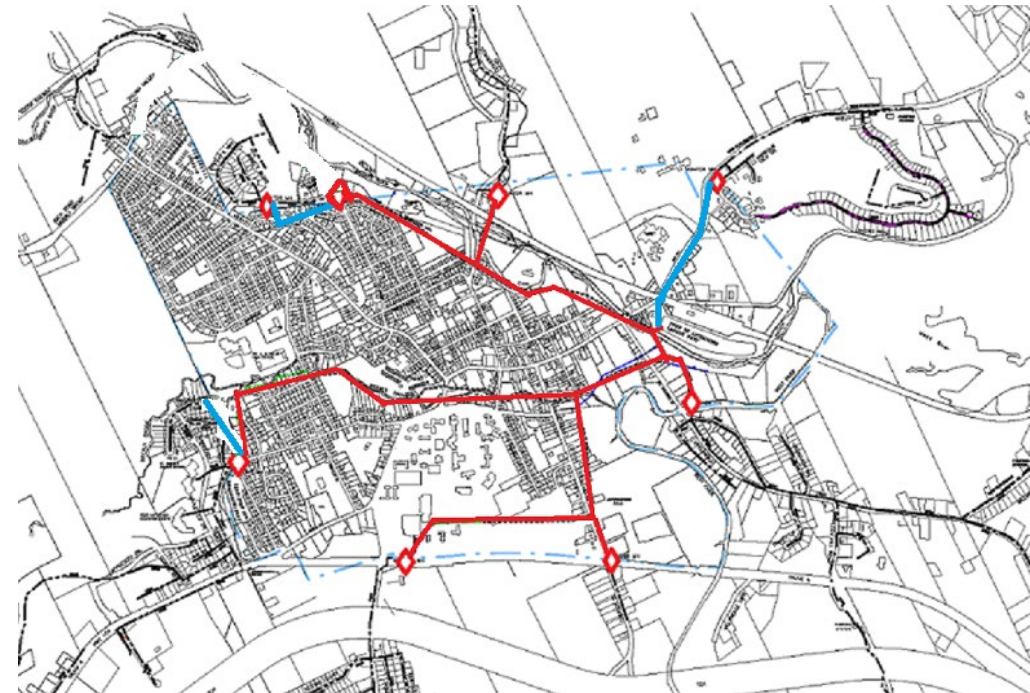

Red = Common lines under Agreement  
Blue = Common lines added after Agreement

# Discussion



# Source Water / Conservation Measures



# Source Water

- James River Dam
  - Last upgraded in 1998 for additional storage
  - Conservation Measures have been enacted 5 times in the last 9 years due to dam levels (3 voluntary, 2 mandatory).
  - Current studies show insufficient storage for 1:20 year drought
- Search for Additional Source Water
  - Studies have been undertaken to assess for other feasible sources of water
  - Test Wells are proposed in the Brierly Brook to James River area
  - The untapped aquifer there may yield up to  $\sim 2,000\text{m}^3/\text{day}$  ( $\sim 50\%$  of current usage)
  - The Housing Accelerator Fund (HAF) includes funding to support source water exploration jointly for the Town and County.
  - Contacts with  $\sim 4$  property owners are underway for drilling permissions.



# Water Conservation Measures

- The dam stopped spilling in the early hours of July 14<sup>th</sup>.
- As per our Water Supply Contingency Plan, we enacted Voluntary Conservation Measures July 17<sup>th</sup> due to a lack of rain in the immediate forecast.
- Voluntary Conservation Measures Mean:
  - The dam has stopped spilling but is less than 1m down from the top of the spillway.
  - We ask people to stop watering their lawns/gardens, washing cars/driveways, etc.
  - The Town leads by example, turning off the splash pad, stopping the flowing of hydrants, and watering of flowers.



# Rainfall and Lifting of Measures

- We received 28mm of rainfall at the dam over the duration of the rain event by Tuesday AM (July 22<sup>nd</sup>)
- Dam levels rose ~1.5ft and by 11:30am Tuesday the dam was spilling once more.
- Conservation measures were lifted as of 11:30am Wednesday, as per the contingency plan.
- The dam has stopped spilling again as of Friday morning (today). Rain is in the forecast, we will monitor and advise. (we need another +15mm)
- A return to voluntary may be required by Monday.



# Questions?

---

